

Preface

Thank you for purchasing KD100 & KD200 series inverters.

This manual describes how to use inverter properly. Please read it carefully before installation, operation, maintenance and inspection. Besides, please use the product after understanding the safety precautions.

Precautions

- In order to describe the product's details, the drawings presented in this instruction are sometimes shown without covers or protective guards. When using the product, please make sure to install the cover or protective guard as specified firstly, and operate the products in accordance with the instructions.
- Since the drawings in this manual are represented examples, some are subject to differ from delivered products.
- This manual may be modified when necessary because of improvement of the product, modification or changes in specifications. Such modifications are denoted by a revised manual No.
- If you want to order the manual due to loss or damage, please contact our company agents in each region or our company customer service center directly.
- If there is still any problem during using the products, please contact our company customer service center directly.

Contents

Chapter 1 Safety and Precautions	- 4 -
1.1 Safety Precautions.....	- 4 -
1.2 Precautions.....	- 7 -
Chapter 2 Product Information	- 10 -
2.1 Product Inspection	- 10 -
2.2 Model Description	- 10 -
2.3 Description of Nameplate.....	- 10 -
2.4 Selection Guide.....	- 11 -
2.5 Technical Specifications	- 12 -
2.6 External and keypad dimensions	- 14 -
2.7 Selection Guide of the external electrical parts	- 16 -
2.8 Routine Maintenance of Inverter	- 18 -
2.9 Instructions on Warranty of Inverter	- 19 -
Chapter 3 Installation and wiring	- 20 -
3.1 Mechanical Installation.....	- 20 -
3.2 Configuration of Peripheral Devices.....	- 22 -
Chapter 4 Operation and Display.....	- 28 -
4.1 Keypad Description.....	- 28 -
4.2 Function Code Checking and Modification Methods Description	- 30 -
4.3 Power-on Initialization.....	- 31 -
4.4 Fault Protection.....	- 31 -
4.5 Stand By	- 31 -
4.6 Running	- 31 -
4.7 Password Setting.....	- 31 -
4.8 Motor Parameters Auto-tuning	- 31 -
4.9 Display setting for F7-03 and P7-04.....	- 32 -
Chapter 5 Examples of Operation.....	- 34 -
5.1 Keypad start, stop, speed adjust by up, down button.....	- 34 -
5.2 Keypad start, stop, speed adjust by keypad potentiometer	- 34 -
5.3 Start/stop by external signal, speed adjust by external potentiometer	- 34 -
5.4 Start/stop by external signal, speed adjust by external 0~10V signal	- 34 -

- 5.5 Start/stop by external signal, speed adjust by external 4~20mA signal..... - 34 -
- 5.6 Increase or decrease the frequency by external digital input - 34 -
- 5.7 Multi-step speed function - 35 -
- 5.8 Terminal command mode..... - 36 -
- 5.9 PID function - 38 -
- Chapter 6 Function Parameter List..... - 39 -**
- 6.1 Basic Function Parameters List - 39 -
- 6.2 Monitoring Parameter Table (U0 group) - 66 -
- Chapter 7 Trouble Shooting - 67 -**
- 7.1 Fault and Trouble Shooting - 67 -
- 7.2 Common Faults and Solutions - 75 -
- Chapter 8 EMC (Electromagnetic Compatibility) - 77 -**
- 8.1 Definition - 77 -
- 8.2 EMC Standard Description - 77 -
- 8.3 EMC Guide - 77 -
- Chapter 9 MODBUS Communication Protocol - 80 -**
- 9.1 About Protocol..... - 80 -
- 9.2 Application Method..... - 80 -
- 9.3 Bus Structure - 80 -
- 9.4 Interfaces and wiring connection..... - 81 -
- 9.5 Protocol Description - 82 -
- 9.6 Communication Data Structure - 82 -
- 9.7 Command Code and Communication Data Description - 83 -
- 9.8 FC Group Communication Parameter Description..... - 92 -

Chapter 1 Safety and Precautions

Safety definition:

In this manual, safety precautions are classified as follows:



 **Danger:** Operations which are not performed according to requirements may cause serious equipment loss or personnel injury.

 **Caution:** Operations which are not performed according to requirements may cause medium hurt or light hurt or material loss.



During the installation, commissioning and maintenance of the system, please make sure to follow the safety and precautions of this chapter. In case of a result of illegal operations, caused any harm and losses is nothing to do with the company.

1.1 Safety Precautions



1.1.1 Before Installation:

 Danger	<ul style="list-style-type: none"> Do not use the water-logged inverter, damaged inverter or inverter with missing parts. Otherwise, there may be risk of injury. Use the motor with Class B or above insulation. Otherwise, there may be risk of electric shock.
 Caution	<ul style="list-style-type: none"> Carefully handled when loading, otherwise it may damage the inverter. Please don't use the damaged driver or inverter with missing parts, there may be risk of injury. Do not touch the electronic parts and components; otherwise it will cause static electricity.



1.1.2 During Installation:

 Danger	<ul style="list-style-type: none"> Install the inverter on incombustible surface such as metal, and keep away from flammable substances. Otherwise it may cause fire. Do not loose the set screw of the equipment, especially the screws marked in RED.
 Caution	<ul style="list-style-type: none"> Do not drop the cable residual or screw in the inverter. Otherwise it may damage the inverter. Please install the driver in the place where there is no direct sunlight or less vibratory. When more than two inverters are to be installed in one cabinet, due attention should be paid to the installation locations (refer to Chapter 3 Mechanical and Electrical Installation) to ensure the heat sinking effect.

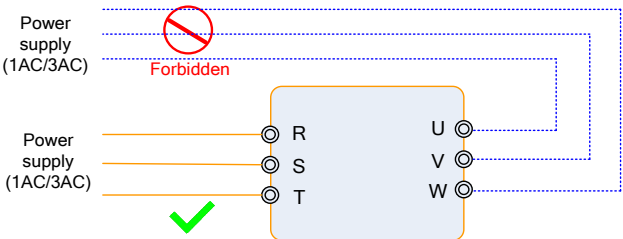

1.1.3 During Wiring:

 Danger	<ul style="list-style-type: none"> ● Operation should be performed by the professional engineering technician. Otherwise there will be danger of electric shock! ● There should be circuit breaker between the inverter and power supply. Otherwise, there may cause fire! ● Make sure the power is disconnected prior to the connection. Otherwise there will be danger of electric shock! ● The ground terminal should be earthed reliably. Otherwise there may be danger of electric shock.
 Caution	<ul style="list-style-type: none"> ● Never connect AC power to output U, V, W terminals. Please note the remark of the wiring terminals, connect them correctly. Otherwise it will cause inverter be damaged. <div data-bbox="296 566 918 805" style="text-align: center;">  <p>The diagram shows a power supply (1AC/3AC) with three lines connecting to terminals R, S, and T. A second power supply (1AC/3AC) is shown with lines that would connect to output terminals U, V, and W. This second connection is crossed out with a red circle and slash, and the word 'Forbidden' is written in red. A green checkmark is placed below the correct R, S, and T connections.</p> </div> <ul style="list-style-type: none"> ● Ensure the wiring circuit can meet the requirement of EMC and the area safety standard. Please follow the instructions in the manual before wiring. Otherwise may cause injury or electric shock. ● Never connect the braking resistor between DC bus (+), (-) terminals. Otherwise may cause fire. ● Encoder must be used together with shielded wire, and ensure the single terminal of the shielded lay is connected with ground well.



1.1.4 Before Power-on:

 Danger	<ul style="list-style-type: none"> ● Please confirm whether the power voltage class is consistent with the rated voltage of the inverter and whether the I/O cable connecting positions are correct, and check whether the external circuit is short circuited and whether the connecting line is firm. Otherwise it may damage the inverter. The cover must be well closed prior to the inverter power-on. Otherwise electric shock may be caused. ● The inverter is free from dielectric test because this test is performed prior to the delivery. Otherwise accident may occur.
 Caution	<ul style="list-style-type: none"> ● The cover must be well closed prior to the inverter power-on. Otherwise electric shock may be caused! ● Whether all the external fittings are connected correctly in accordance with the circuit provided in this manual. Otherwise accident may occur!

1.1.5 After Power-on:

 Danger	<ul style="list-style-type: none"> ● Do not open the cover of the inverter upon power-on. Otherwise there will be danger of electric shock! ● Do not touch the inverter and its surrounding circuit with wet hand. Otherwise there will be danger of electric shock! ● Do not touch the inverter terminals (including control terminal). Otherwise there will be danger of electric shock! ● At power-on, the inverter will perform the security check of the external heavy-current circuit automatically. Thus, at the moment please do not touch the terminals U, V and W, or the terminals of motor, otherwise there will be danger of electric shock.
 Caution	<ul style="list-style-type: none"> ● If parameter identification is required, due attention should be paid to the danger of injury arising from the rotating motor. Otherwise accident may occur! ● Do not change the factory settings at will. Otherwise it may damage the equipment!

1.1.6 During Operation:

 Danger	<ul style="list-style-type: none"> ● Do not touch the fan or discharge resistor to sense the temperature. Otherwise, you may get burnt! ● Detection of signals during the operation should only be conducted by qualified technician. Otherwise, personal injury or equipment damage may be caused!
 Caution	<ul style="list-style-type: none"> ● During the operation of the inverter, keep items from falling into the equipment. Otherwise, it may damage the equipment! ● Do not start and shut down the inverter by connecting and disconnecting the contactor. Otherwise, it may damage the equipment!

1.1.7 During Maintain:

 Danger	<ul style="list-style-type: none"> ● Do not repair and maintain the equipment with power connection. Otherwise there will be danger of electric shock! ● Be sure to conduct repair and maintenance after the charge LED indicator of the inverter is OFF. Otherwise, the residual charge on the capacitor may cause personal injury! ● The inverter should be repaired and maintained only by the qualified person who has received professional training. Otherwise, it may cause personal injury or equipment damage! ● Carry out parameter setting after replacing the inverter, all the plug-ins must be plug and play when power outage.
---	---

1.2 Precautions

1.2.1 Motor Insulation Inspection

When the motor is used for the first time, or when the motor is reused after being kept, or when periodical inspection is performed, it should conduct motor insulation inspection so as to avoid damaging the inverter because of the insulation failure of the motor windings. The motor wires must be disconnected from the inverter during the insulation inspection. It is recommended to use the 500V megameter, and the insulating resistance measured should be at least 5MΩ.

1.2.2 Thermal Protection of the Motor

If the ratings of the motor does not match those of the inverter, especially when the rated power of the inverter is higher than the rated power of the motor, the relevant motor protection parameters in the in the inverter should be adjusted, or thermal relay should be mounted to protect the motor.

1.2.3 Running with Frequency higher than Standard Frequency

This inverter can provide output frequency of 0Hz to 600Hz. If the user needs to run the inverter with frequency of more than 50Hz, please take the resistant pressure of the mechanical devices into consideration.

1.2.4 Vibration of Mechanical Device

The inverter may encounter the mechanical resonance point at certain output frequencies, which can be avoided by setting the skip frequency parameters in the inverter.

1.2.5 Motor Heat and Noise

Since the output voltage of inverter is PWM wave and contains certain harmonics, the temperature rise, noise and vibration of the motor will be higher than those at power frequency.

1.2.6 Voltage-sensitive Device or Capacitor Improving Power Factor at the Output Side

Since the inverter output is PWM wave, if the capacitor for improving the power factor or voltage-sensitive resistor for lightning protection is mounted at the output side, it is easy to cause instantaneous over current in the inverter, which may damage the inverter. It is recommended that such devices not be used.

1.2.7 Switching Devices like Contactors Used at the Input and Output terminal

If a contactor is installed between the power supply and the input terminal of the inverter, it is not allowed to use the contactor to control the startup/stop of the inverter. If such contactor is unavoidable, it should be used with interval of at least one hour. Frequent charge and discharge will reduce the service life of the capacitor inside the inverter. If switching devices like contactor are installed between the output end of the inverter and the motor, it should ensure that the on/off operation is conducted when the inverter has no output. Otherwise the modules in the inverter may be damaged.

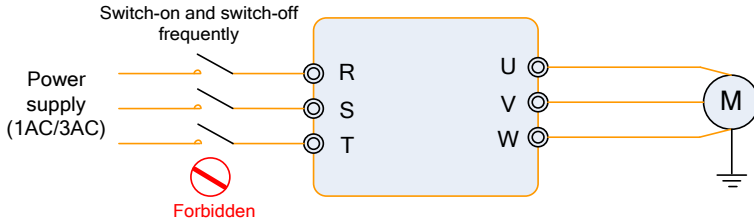

1.2.8 Use under voltage rather than rated voltage

If the KD100 & KD200 series inverter is used outside the allowable working voltage range as specified in this manual, it is easy to damage the devices in the inverter. When necessary, use the corresponding step-up or step-down instruments to change the voltage.

1.2.9 Change Three-phase Input to Two-phase Input

It is not allowed to change the KD100 & KD200 series three-phase inverter into two-phase one. Otherwise, it may cause fault or damage to the inverter.

1.2.10 Lightning Impulse Protection

The series inverter has lightning over current protection device, and has certain self-protection capacity against the lightning. In applications where lightning occurs frequently, the user should install additional protection devices at the front-end of the inverter.

1.2.11 Altitude and Derating

In areas with altitude of more than 1,000 meters, the heat sinking effect of the inverter may turn poorer due to rare air. Therefore, it needs to derate the inverter for using. Please make selection as the below derating diagram.

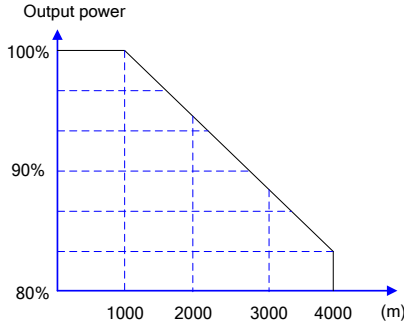

1.2.12 Certain Special Use

If the user needs to use the inverter with the methods other than the recommended wiring diagram in this manual, such as shared DC bus, please consult our company.

1.2.13 Note of Inverter Disposal

The electrolytic capacitors on the main circuit and the PCB may explode when they are burnt. Emission of toxic gas may be generated when the plastic parts are burnt. Please dispose the inverter as industrial wastes.

1.2.14 Adaptable Motor

- 1) The standard adaptable motor is four-pole squirrel-cage asynchronous induction motor. If such motor is not available, be sure to select adaptable motors in according to the rated current of the motor. In applications where drive permanent magnetic synchronous motor is required, please consult our company;
- 2) The cooling fan and the rotor shaft of the non-variable-frequency motor adopt coaxial connection. When the rotating speed is reduced, the cooling effect will be poorer. Therefore, a powerful exhaust fan should be installed, or the motor should be replaced with variable frequency motor to avoid the over heat of the motor.
- 3) Since the inverter has built-in standard parameters of the adaptable motors, it is necessary to perform motor parameter identification or modify the default values so as to comply with the actual values as much as possible, or it may affect the running effect and protection performance;
- 4) The short circuit of the cable or motor may cause alarm or explosion of the inverter. Therefore, please conduct insulation and short circuit test on the newly installed motor and cable. Such test should also be conducted during routine maintenance. Please note that the inverter and the test part should be completely disconnected during the test.

Chapter 2 Product Information

2.1 Product Inspection

Checking the following items when receiving the inverter

Confirmation Items	Method
Confirm if the inverter is what you ordered	Check name plate
Damaged or not	Inspect the entire exterior of the inverter to see if there are any scratches or other damage resulting from shipping
Confirm if the fastening parts (screws, etc.) are loose or not	Check with a screw driver if necessary
User's manual, certification and other spares	User's manual and the relative spares

Please contact the local agent or our company directly if there is any damage on the inverter.

2.2 Model Description

KD200 - 00075 S 2

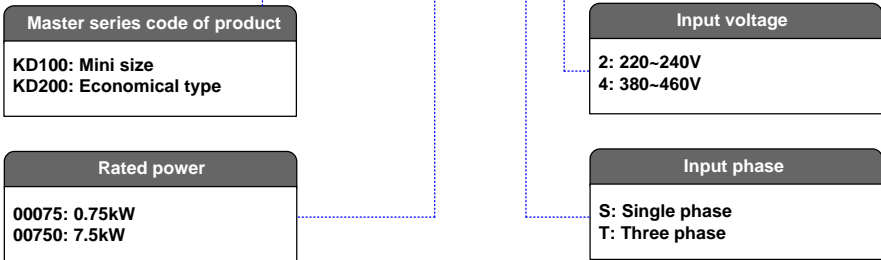

2.3 Description of Nameplate

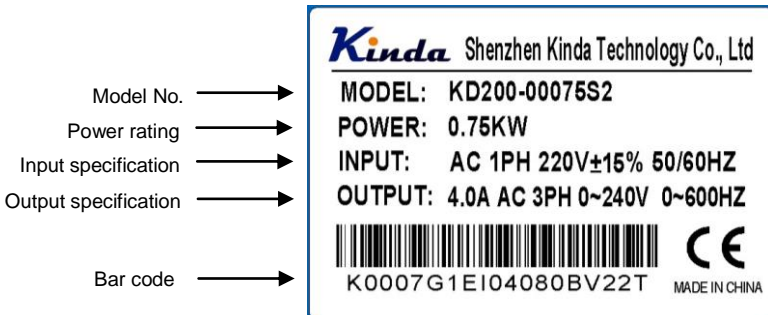

2.4 Selection Guide

(1) KD100

Inverter Model	Motor		Rated Input Current (A)	Rated Output Current (A)
	kW	HP		
1AC 220~240V ±15%				
KD100-00004S2	0.4	0.5	5.4	2.3
KD100-00075S2	0.75	1	8.2	4
KD100-00150S2	1.5	2	14	7
3AC 380~415V ±15%				
KD100-00075T4	0.75	1	3.4	2.5
KD100-00150T4	1.5	2	5.0	4.2

(2) KD200

Inverter Model	Motor		Rated Input Current (A)	Rated Output Current (A)
	kW	HP		
1AC 220~240V±15%				
KD200-00075S2	0.75	1	8.2	4
KD200-00150S2	1.5	2	14	7
KD200-00220S2	2.2	3	24	9.6
3AC 220~240V±15%				
KD200-00075T2	0.75	1	5	4
KD200-00150T2	1.5	2	9.5	7
KD200-00220T2	2.2	3	11	9.6
KD200-00400T2	4.0	5	20.5	17
3AC 380~460V±15%				
KD200-00075T4	0.75	1	3.4	2.5
KD200-00150T4	1.5	2	5.0	4.2
KD200-00220T4	2.2	3	5.8	5.5
KD200-00400T4	4.0	5	11	9.5
KD200-00550T4	5.5	7.5	14.6	13
KD200-00750T4	7.5	10	20.5	17

2.5 Technical Specifications

Item	Technical Index	Specification
Input	Input voltage	1AC/3AC 220~240V±15%, 3AC 380~460V±15%
	Input frequency	50/60Hz±5%
Output	Output voltage	0~rated input voltage
	Output frequency	0~600Hz
Control Features	Control mode	V/f control Sensorless vector control Torque control
	Operation command mode	Keypad control Terminal control Serial communication control (Modbus)
	Frequency setting mode	Digital setting, analog setting, pulse frequency setting, serial communication setting, multi-step speed setting & simple PLC, PID setting, etc. These frequency settings can be combined & switched in various modes.
	Overload capacity	150% / 60s, 180% / 10s, 200% / 1s.
	Starting torque	0.25Hz/150% (SVC); 0.5Hz/150% (V/f)
	Speed control precision	±0.5% (SVC)
	Carrier frequency	0.5~16.0kHz, automatically adjusted according to temperature and load characteristics
	Frequency accuracy	Digital setting: 0.01Hz Analog setting: maximum frequency ×0.05%
	Torque boost	Automatically torque boost; manually torque boost: 0.1%~30.0%
	V/f curve	Three types: linear, multiple point and square type (1.2 power, 1.4 power, 1.6 power, 1.8 power, square)
	Acceleration/deceleration mode	Straight line/S curve; four kinds of acceleration/deceleration time, range: 0.1s~6553s
	Braking unit	KD100: Doesn't build-in, not available for braking KD200: Standard build-in
	DC braking	DC braking when starting and stopping DC braking frequency: 0.0Hz~maximum frequency, braking time: 0.0s~25.0s
	Jog operation	Jog operation frequency: 0.0Hz~maximum frequency Jog acceleration/deceleration time: 0.1s~3600.0s
Simple PLC & multi-step speed operation	It can realize a maximum of 16 multi-step speeds running via the built-in PLC or control terminal.	

	Built-in PID	Built-in PID control to easily realize the close loop control of the process parameters (such as pressure, temperature, flow, etc.)
	Automatic voltage regulation	Keep output voltage constant automatically when input voltage fluctuating
Control Function	Torque control	Torque control without PG
	Torque limit	“Rooter” characteristics, limit the torque automatically and prevent frequent over-current tripping during the running process
	Wobble frequency control	Multiple triangular-wave frequency control, special for textile
	Timing/length/counting control	Timing/length/counting control function
	Over-voltage & over-current stall control	Limit current & voltage automatically during the running process, prevent frequent over-current & over-voltage tripping
	Fault protection function	Comprehensive protections include over-current, over-voltage, under-voltage, overheating, default phase, overload, shortcut, etc., can record the detailed running status during failure & has fault automatic reset function
Input/output terminals	Input terminals	Programmable digital input: 5 multifunctional inputs 2 programmable analog input: VI: 0~10V CI: 4~20mA
	Output terminals	Refer to typical wiring for details
	Communication terminals	Offer RS485 communication interface, support MODBUS-RTU communication protocol
Human machine interface	LED display	Display frequency setting, output frequency, output voltage, output current, etc. Two lines display
	Multifunction key	QUICK/JOG key, can be used as multifunction key
Environment	Ambient temperature	-10°C~50°C, without direct sunshine.
	Humidity	90%RH or less (non-condensing)
	Altitude	≤1000M: output rated power, >1000M: output derated
	Storage temperature	-20°C~60°C

2.6 External and keypad dimensions

A: 0.4~2.2kW

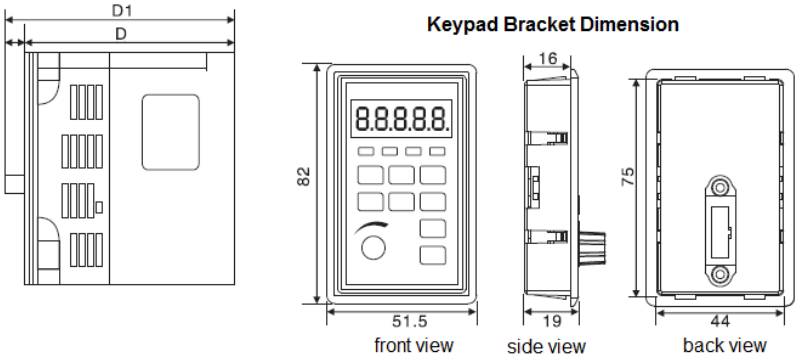
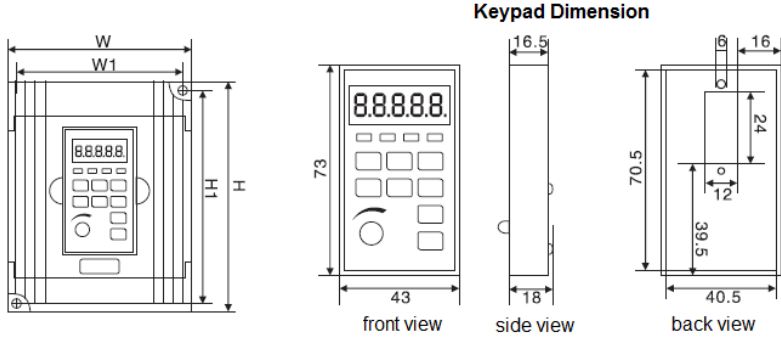

Model	H1	H	W	W1	D	D1
KD100-00004S2	132	142	85.5	74	113	123
KD100-00075S2						
KD100-00150S2						
KD100-00075T4						
KD100-00150T4	143	152	101	92	117	127
KD200-00075S2 (T2)						
KD200-00150S2 (T2)						
KD200-00220S2 (T2)						
KD200-00075T4						
KD200-00150T4						
KD200-00220T4						

B: 4~7.5kW

Keypad Dimension

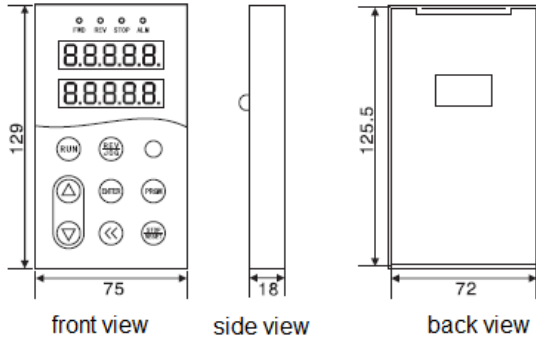
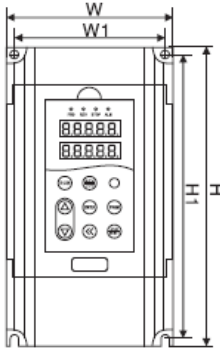

Keypad Bracket Dimension

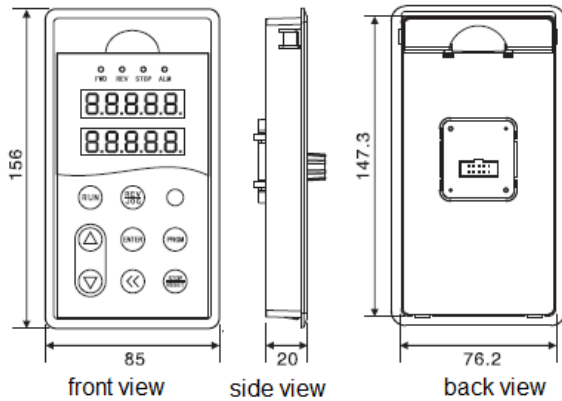
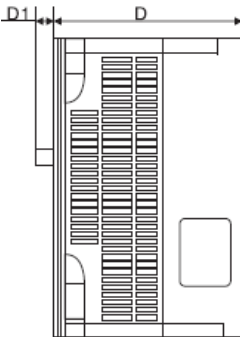

Model	W	W1	H	H1	D	D1
KD200-00400T2	130	115	264	244	153.5	9
KD200-00400T4						
KD200-00550T4						
KD200-00750T4						

2.7 Selection Guide of the external electrical parts

(1) Selection guide of electric cable

Inverter Model	Circuit Breaker (MCCB) (A)	Recommended Contactor A	Recommended Conducting Wire of Main Circuit at Input Side (mm ²)	Recommended Conducting Wire of Main Circuit at Output Side (mm ²)	Recommended Conducting Wire of Control Circuit (mm ²)
1AC 220~240V					
KD100-00004S2	16	10	2.5	2.5	1.0
KD100-00075S2	16	10	2.5	2.5	1.0
KD100-00150S2	20	16	4.0	2.5	1.0
KD200-00075S2	16	10	2.5	2.5	1.0
KD200-00150S2	20	16	4.0	2.5	1.0
KD200-00220S2	32	20	6.0	4.0	1.0
3AC 220~240V					
KD200-00075T2	16	10	2.5	2.5	1.0
KD200-00150T2	20	16	4.0	4.0	1.0
KD200-00220T2	32	20	4.0	4.0	1.0
KD200-00400T2	40	32	4.0	4.0	1.0
3AC 380~460V					
KD100-00075T4	10	10	2.5	2.5	1.0
KD100-00150T4	16	10	2.5	2.5	1.0
KD200-00075T4	10	10	2.5	2.5	1.0
KD200-00150T4	16	10	2.5	2.5	1.0
KD200-00220T4	16	10	2.5	2.5	1.0
KD200-00400T4	25	16	4.0	4.0	1.0
KD200-00550T4	32	25	4.0	4.0	1.0
KD200-00750T4	40	32	4.0	4.0	1.0

(2) Selection guide of braking system
a. 1AC/3AC 220V

Inverter Model	Braking unit		Braking unit (100% of the braking torque, 10% of the utilization rate)		
	Specification	Quantity	Equivalent braking resistor	Equivalent braking power	Quantity
KD100-00004S2	Not available for braking				
KD100-00075S2					
KD100-00150S2					
KD200-00075S2 (T2)	Build-in	1	150Ω	80W	1
KD200-00150S2 (T2)		1	100Ω	100W	1
KD200-00220S2 (T2)		1	70Ω	100W	1
KD200-00400S2		1	48Ω	400W	1

b. 3AC 220V

Inverter Model	Braking unit		Braking unit (100% of the braking torque, 10% of the utilization rate)		
	Specification	Quantity	Equivalent braking resistor	Equivalent braking power	Quantity
KD200-00075T2	Build-in	1	150Ω	100W	1
KD200-00150T2		1	130Ω	260W	1
KD200-00220T2		1	80Ω	260W	1
KD200-00400T2		1	48Ω	400W	1

c. 3AC 380V

Inverter Model	Braking unit		Braking unit (100% of the braking torque, 10% of the utilization rate)		
	Specification	Quantity	Equivalent braking resistor	Equivalent braking power	Quantity
KD100-00075T4	Not available for braking				
KD100-00150T4					
KD200-00075T4	Build-in	1	300Ω	150W	1
KD200-00150T4		1	220Ω	260W	1
KD200-00220T4		1	150Ω	390W	1
KD200-00400T4		1	150Ω	390W	1

Inverter Model	Braking unit		Braking unit (100% of the braking torque, 10% of the utilization rate)		
	Specification	Quantity	Equivalent braking resistor	Equivalent braking power	Quantity
KD200-00550T4		1	100Ω	520W	1
KD200-00750T4		1	50Ω	1040W	1

d. Wiring connection of braking system of KD200

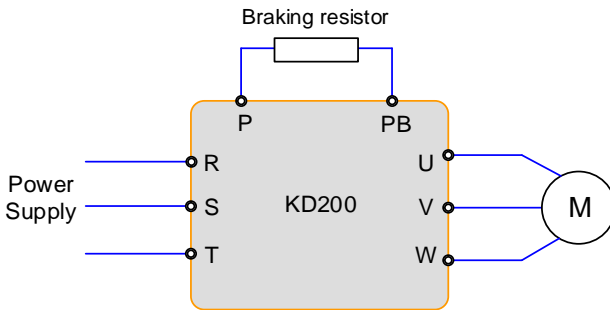

2.8 Routine Maintenance of Inverter

2.8.1 Routine Maintenance

The influence of the ambient temperature, humidity, dust and vibration will cause the aging of the devices in the inverter, which may cause potential fault of the inverter or reduce the service life of the inverter. Therefore, it is necessary to carry out routine and periodical maintenance on the inverter.

Routine inspection Items include:

- 1) Whether there is any abnormal change in the running sound of the motor;
- 2) Whether the motor has vibration during the running;
- 3) Whether there is any change to the installation environment of the inverter;
- 4) Whether the inverter cooling fan works normally;
- 5) Whether the inverter has over temperature.

Routine cleaning:

- 1) The inverter should be kept clean all the time.
- 2) The dust on the surface of the inverter should be effectively removed, so as to prevent the dust entering the inverter. Especially the metal dust is not allowed.
- 3) The oil stain on the inverter cooling fan should be effectively removed.

2.8.2 Periodic Inspection

Please perform periodic inspection on the places where the inspection is a difficult thing.

Periodic inspection Items include:

- 1) Check and clean the air duct periodically;
- 2) Check if the screws are loose;
- 3) Check if the inverter is corroded;
- 4) Check if the wire connector has arc signs;
- 5) Main circuit insulation test.

Remainder: When using the megameter (DC 500V megameter recommended) to measure the insulating resistance, the main circuit should be disconnected with the inverter. Do not use the insulating resistance meter to test the insulation of control circuit. It is not necessary to conduct the high voltage test (which has been completed upon delivery).

2.8.3 Storage of Inverter

Upon acquiring the inverter, the user should pay attention to the following points regarding the temporary and long-term storage of the inverter:

- 1) Pack the inverter with original package and place back into the packing box of our company.
- 2) Long-term storage will degrade the electrolytic capacitor. Thus, the product should be powered up once every 2 years, each time lasting at least five hours. The input voltage should be increased slowly to the rated value with the regulator.

2.9 Instructions on Warranty of Inverter

Free warranty only applies to the inverter itself.

- 1) Kinda provides 20 month warranty (starting from the date of original shipment as indicated on the barcode) for the failure or damage under normal use conditions. If the equipment has been used for over 20 months, reasonable repair expenses will be charged.
- 2) Reasonable repair expenses will be charged for the following situations within 20 months:
 - a) The equipment is damaged because the user fails to comply with the requirements of the user's manual;
 - b) Damage caused by fire, flood and abnormal voltage;
- 3) Damage caused when the inverter is used for abnormal function.

The service expenses will be calculated according to the standard of the manufacturer. If there is any agreement, the agreement should prevail.

Chapter 3 Installation and wiring

3.1 Mechanical Installation

3.1.1 Installation environment

- 1) Ambient temperature: The ambient temperature exerts great influences on the service life of the inverter and is not allowed to exceed the allowable temperature range (-10°C to 50°C).
- 2) The inverter should be mounted on the surface of incombustible articles, with sufficient spaces nearby for heat sinking. The inverter is easy to generate large amount of heat during the operation. The inverter should be mounted vertically on the base with screws.
- 3) The inverter should be mounted in the place without vibration or with vibration of less than 0.6G, and should be kept away from such equipment as punching machine.
- 4) The inverter should be mounted in locations free from direct sunlight, high humidity and condensate.
- 5) The inverter should be mounted in locations free from corrosive gas, explosive gas or combustible gas.
- 6) The inverter should be mounted in locations free from oil dirt, dust, and metal powder.

3.1.2 Installation diagram

a. Multiple inverters parallel installation

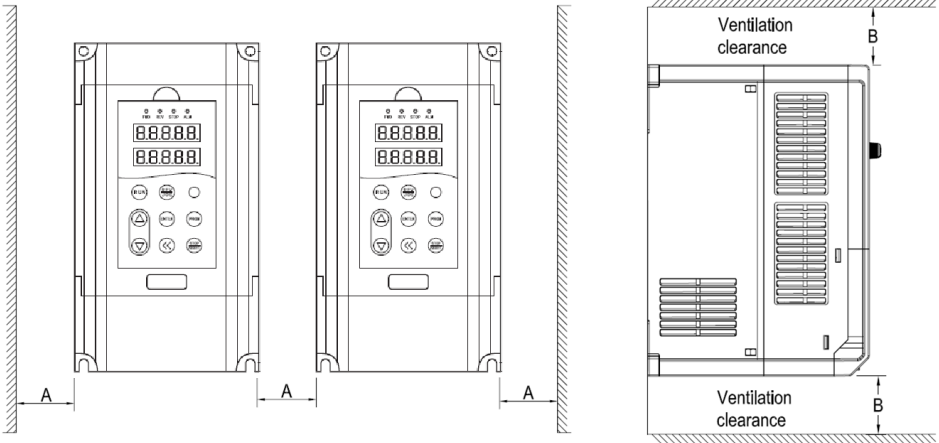

b. Multiple inverters vertical installation

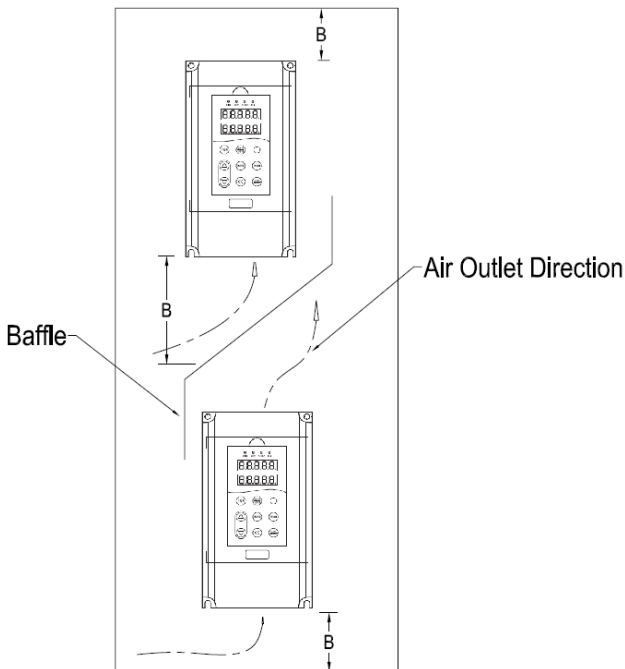

Requirement of minimum mounting clearances

Drive model	Mounting clearances (mm)	
	A	B
0.4~7.5kW	≥50	≥100



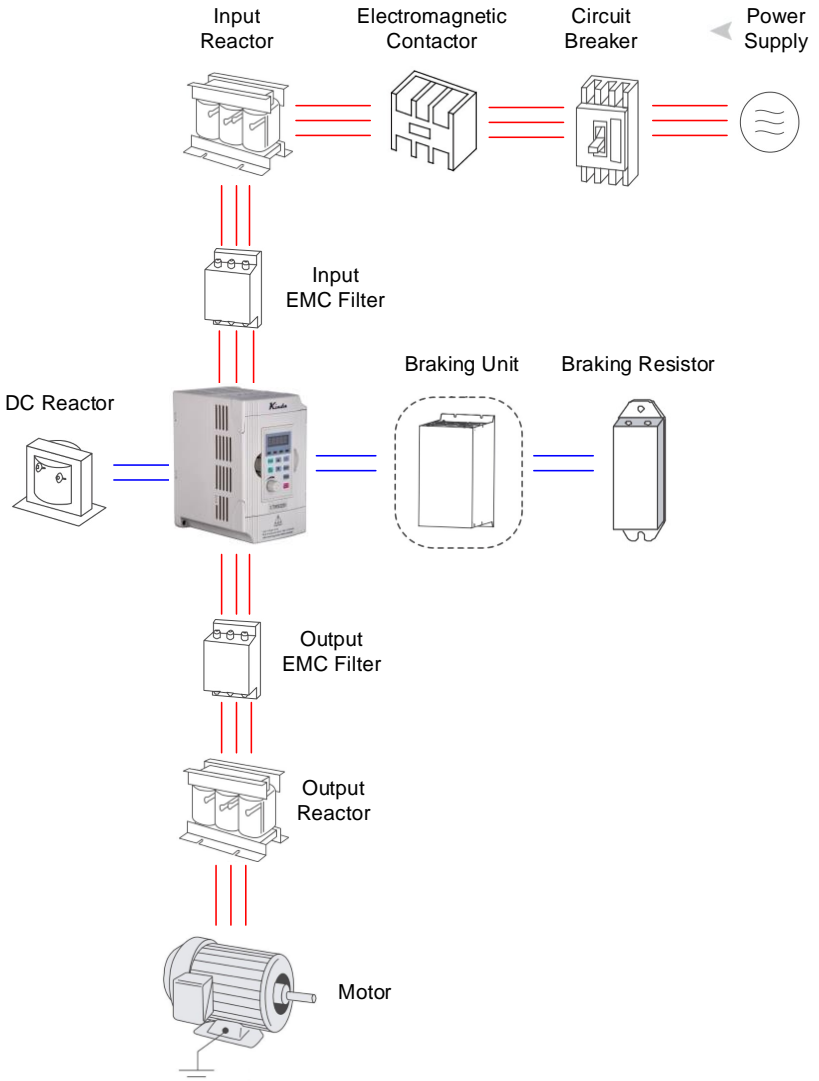

3.1.3 Heat dissipation should be taken into account during the mechanical installation. Please pay attention the following items:

- 1) Install the inverter vertically so that the heat may be expelled from the top. However, the equipment cannot be installed upside down. If there are multiple inverters, parallel installation is a better choice. In applications where the upper and lower inverters need to be installed, please refer to 3.1.2 “KD100 & KD200 series Inverter Installation Diagram” and install an insulating splitter.
- 2) The mounting space should be as indicated as 3.1.2, so as to ensure the heat dissipation space of the inverter. However, the heat dissipation of other devices in the cabinet should also be taken into account.
- 3) The installation bracket must be flame retardant.
- 4) In the applications where there are metal dusts, it is recommended to mount the radiator outside the cabinet. In this case, the space in the sealed cabinet should be large enough.

3.2 Configuration of Peripheral Devices

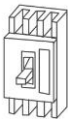
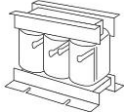

Instructions of peripheral devices

Picture	Device	Instructions
	Cable	Transmitting electrical signals.
	Circuit breaker	Purpose: disconnect power supply and protect the equipment in case of abnormal overcurrent occurs Type selection: breaking current of circuit breaker is defined to be 1.5~2 times the rated current of the drive Breaking time characteristic of circuit breaker should be selected based on overload protection time characteristic of the drive
	Input reactor	Improve power factor. Reduce the impact of imbalanced three-phase input AC power supply on the system Suppress higher harmonics and reduce the conducted and radiated interference to peripheral devices Restrict the impact of impulse current on rectifier bridges.
	Input EMC filter	Reduce conducted interference from power supply to the drive, improve the immunity of the drive from noise Reduce conducted and radiated interference of the drive to peripheral device
	Braking resistor	Purpose: consume motor feedback energy to realize quick brake
	Output EMC filter	Output filter and radiated interference of the drive to peripheral devices
	Output reactor	Avoid the motor insulation damage result from harmonic voltage Reduce frequent protection from the drive caused by leakage current In case the cable connecting drive and motor is over 100 meters, output AC reactor recommended

- Do not install the capacitor or surge suppressor at the output side of the inverter, otherwise it may cause inverter failure or capacitor and surge suppressor damaged.
- The Inverter input / output (main circuit) contains harmonic components, it may interfere with inverter accessories communications equipment. Therefore, please install anti-interference filter to minimize interference.
- The details of external devices and accessories selection refer to the manual of external devices.

3.2.4 Wiring diagram

a. KD100 Wiring Diagram

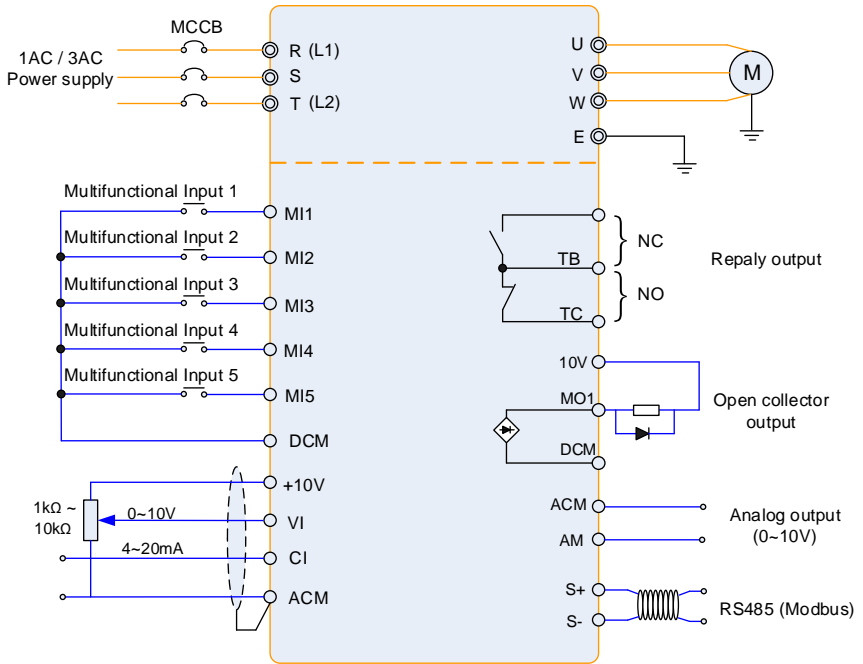

b. KD200 Wiring Diagram

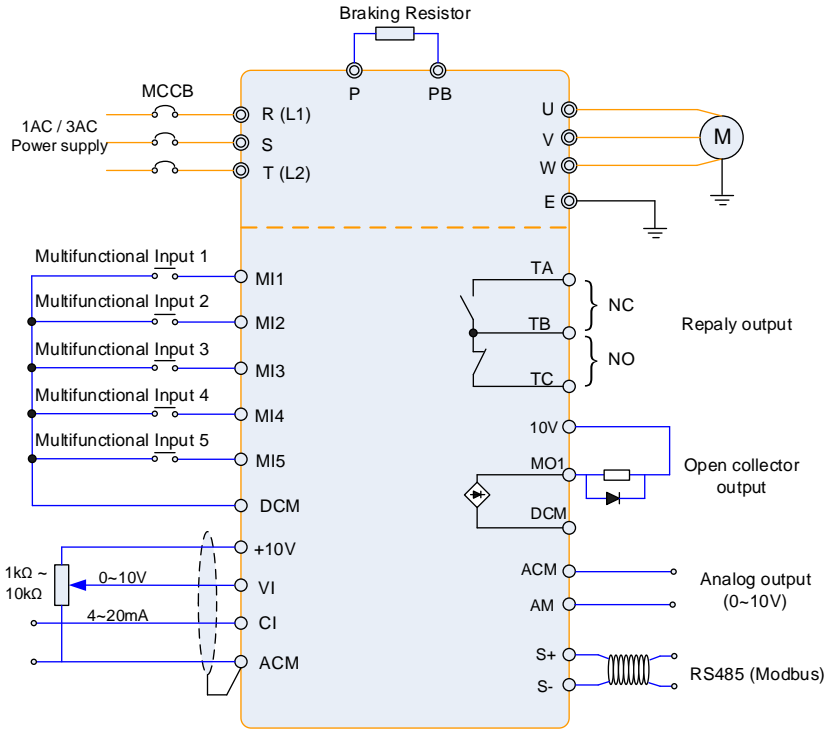

Note:

1. Terminal © refers to the main circuit terminal, terminal O refers to the control circuit terminal.
2. Built-in braking unit is standard in the inverters below 18.5kW (include).
3. Braking resistor is optional for user.

3.2.5 Main circuit terminals and connections

Danger
<ul style="list-style-type: none"> ● Make sure that the power switch is at OFF status prior to perform wiring connection. Otherwise there may be danger of electric shock! ● Only the qualified and trained personnel can perform wiring connection. Otherwise it may cause equipment and human injuries! ● It should be earthed reliably. Otherwise there may be danger of electric shock or fire!

	<p>Caution</p> <ul style="list-style-type: none"> ● Make sure that the rated value of the input power supply is consistent with that of the inverter. Otherwise it may damage the inverter! ● Make sure that the motor matches the inverter. Otherwise it may damage the motor or generate inverter protection! ● Do not connect the power supply to the terminals of U, V and W. Otherwise it may damage the inverter! ● Do not directly connect the brake resistor between the DC bus terminals (+) and (-). Otherwise it may cause fire!
---	--

Instructions of main circuit terminals

Terminal	Description
L1, L2	Connect to single phase AC power
R, S, T	Connect to three-phase AC power
P, PB	Reserved terminals for braking resistor (KD200)
U, V, W	Connect to three phase motor
	Ground connection terminal

3.2.6 Control terminals and connections

1) 0.4~2.2kW Control circuit terminals

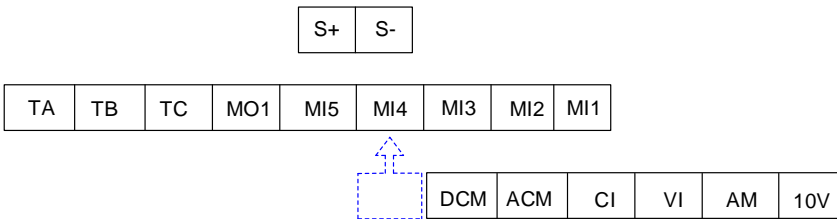

2) 4~7.5kW Control circuit terminals

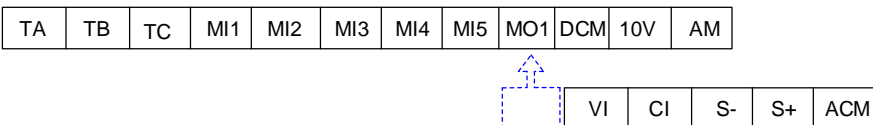

3.2.7 Description of jumpers on control board

Jumper	connection	Description
J14	Short connect 1 & 2	Connect RS485 terminal resistor
	Short connect 2 & 3	Disconnect RS485 terminal resistor

Description of Control Terminal Function

Type	Terminal Symbol	Terminal Name	Function Description
Power Supply	+10V~ACM	External +10V power	Provide +10V power supply for external units, and the maximum output current is 100mA. It is generally used as the operating power supply for the external potentiometer. The potentiometer resistance range is 1kΩ~10kΩ.
Analog Input	VI~ACM	Analog input terminal 1	1. Input range: 0V~10V. 2. Input impedance: 2.2kΩ.
	CI~ACM	Analog input terminal 2	1. Input range: 4~20mA, 2. Input impedance: 500Ω.
Digital Input	MI1	Digital input 1	1. Optical coupling isolation, compatible with dual polarity input 2. Input impedance: 2.4kΩ 3. Voltage range for level input: 9V~30V
	MI2	Digital input 2	
	MI3	Digital input 3	
	MI4	Digital input 4	
	MI5	Digital input 5	
Digital Output	AM~ACM	Analog output 1	The voltage or current output is determined by J5 jumper on the control board. Output voltage range: 0V ~ 10V.
Digital Output	MO1	Open collector output	Correspond common terminal is DCM. External connection voltage range: 0~24V Output current range: 0mA~50mA
Relay Output 1	TB-TC	Normally close terminal	Driving capacity: AC 250V/3A, DC 30V/1A
	TB-TA	Normally open terminal	
RS485	S+	RS485+	Communication interface of Modbus, it is suggested to use twisted-pair cable or shielded cable.
	S-	RS485-	

Chapter 4 Operation and Display

4.1 Keypad Description

With the operation keypad, it can perform such operations on the inverter as function parameter modification, working status monitor and running control (start and stop).

(1) Keypad of KD100

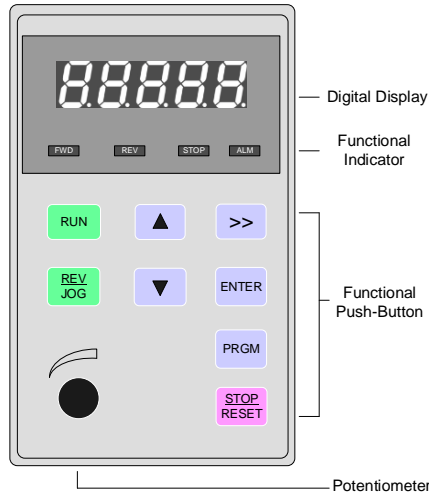

(2) Keypad of KD200

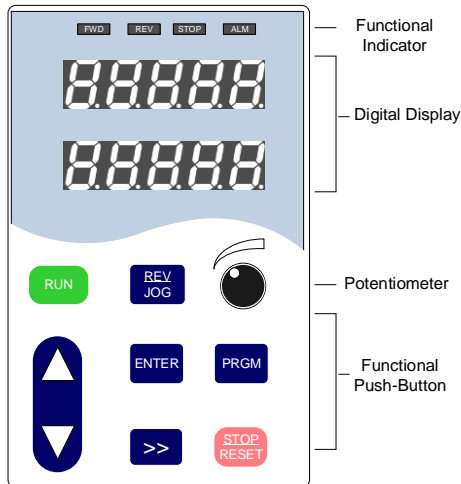

1) Function keys description







Functional indicator	Description
FWD	Indication of inverter forward running
REW	Indication of inverter reverse running
STOP	Inverter is stopping
ALM	Inverter with fault



2) Digital display zone

Five-number digit LED display, can display setting frequency, output frequency, various monitoring data and alarm code.

The first line LED display of two lines keypad is operated and displayed the same like single line LED keypad. The second line LED displays the parameters of F7-08, the default value is 04, displays the output current. If customers need to display other parameters, just change F7-08.

3) Keypad push-button description

Button	Name	Function
	Programming key	Entry and exit of primary menu
	Confirmation key	Progressively enter menu, and confirm parameters
	Increment key	Progressively increase of data or function codes
	Decrement key	Progressively decrease of data or function codes
	Shift key	Select the displayed parameters in turn on the stop display interface and running display interface, and select the modification bit of parameters when modifying parameters.
	Running key	Start to run inverter under keyboard control mode

	Stop / Reset	Stop inverter in running status and reset operation in fault alarm status. The reactions are controlled by F7-02.
	Multi-function selection key	The corresponding functions are defined by F7-01.

4.2 Function Code Checking and Modification Methods Description

The operation keypad of the KD100 & KD200 series Inverter adopts three-level menu structure to carry out operations such as parameter setting.

- 1) Function parameter group (level 1 menu)
- 2) Function code (level 2 menu)
- 3) Function code setting value (level 3 menu)

Description: When operating on level 3 menu, press **PRGM** key or **ENTER** key to return to level 2 menu. The difference between **PRGM** key and **ENTER** key is described as follows:

- 1) Pressing **ENTER** key will save the setup parameter and return to the level 2 menu and then automatically shift to the next function code.
- 2) Pressing **PRGM** key will directly return to level 2 menu without saving the parameter, and it will return to the current function code.

Example: Modify the function code F1-03 from 00.00Hz to 05.00Hz.

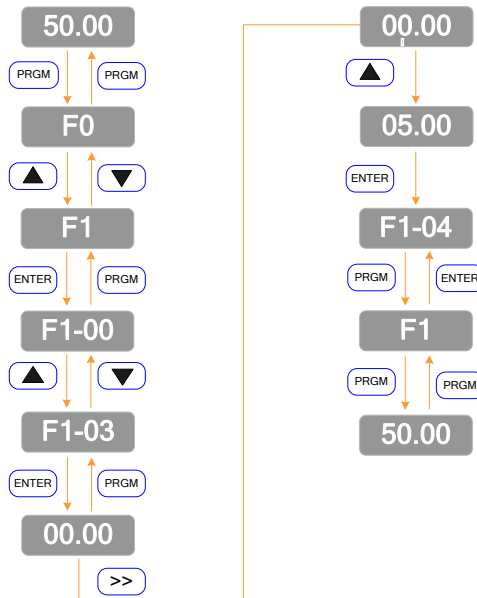

In level 3 menu, if there is no flashing bit, it means this function code cannot be modified. The possible

reasons are:

- 1) The function code is an unchangeable parameter, such as actual detection parameter, running record parameter, etc.
- 2) The function code cannot be modified in running status. It can be modified only when the inverter is stopped.

4.3 Power-on Initialization

Firstly the system initializes during the inverter power-on, and LED displays "8.8.8.8.8". After initialization, the inverter is in fault protection status if a fault happens, or the inverter is in stand-by status

4.4 Fault Protection

In fault status, inverter will display fault code & record output current, output voltage, etc. For details, please refer to FA (fault and protection) parameter group. Fault can be reset via STOP/RESET key or external terminals.

4.5 Stand By

In stop or stand by status, parameters of multi-status can be displayed. Whether or not to display this parameter can be chosen through function code F7-05 (Stop status display parameter) according to binary bits.

The displaying of the chosen parameters can be switched in sequence by pressing  button.

4.6 Running

In running status, there are thirty two parameters can be chosen to display or not through function code F7-03 and F7-04 (running status display parameter) according to binary bits.

The displaying of the chosen parameters can be switched in sequence by pressing  button.

4.7 Password Setting

The inverter provides user password protection function. When F7-00 is set to non-zero value, it indicates the user password, and the password protection turns valid after 1 minute of setting the password. When pressing **PRGM** key again, "00000" will be displayed, and common menu cannot be entered until user password is input correctly.

To cancel the password protection function, enter with password and set F7-00 to "0".

4.8 Motor Parameters Auto-tuning

To select the vector control running mode, it must input the nameplate parameter of the motor accurately prior to the running of the inverter. The Inverter will select standard motor parameters matching the nameplate parameter. Since the vector control mode relies highly on the motor parameters, it must acquire the accurate parameters of the controlled motor to ensure the good control performance.

The procedures for the automatic tuning of motor parameters are described below:

First, select the command source (F0-02) as the command channel of the operation keypad. Second, input the following parameters in accordance with the actual motor parameters:

F2-01: Rated motor power

- F2-02: Rated motor voltage
- F2-03: Rated motor current
- F2-04: Rated motor frequency
- F2-05: Rated rotation speed of motor

If the motor is completely disconnected from the load, set F2.11 to “2” (complete tuning), and press **RUN** key on the keypad, it will display “RUN”, motor will rotate, and it will stop automatically while auto-tuning finish, the keypad will display “END”. After auto-tuning the following parameters will be updated:

- F2-06: Stator resistance
- F2-07: Rotor resistance
- F2-08: Leakage inductance
- F2-09: Mutual inductance
- F2-10: Current without load

Finally, complete the automatic tuning of motor parameters.

If the motor cannot be completely disconnected with the load, set F2-11 to “1” (static tuning), and then press **RUN** key on the keyboard panel, wait until the auto-tuning finish.

The following motor parameters will be updated automatically:

- F2-06: Stator resistance
- F2-07: Rotor resistance
- F2-08: Leakage inductive reactance

4.9 Display setting for F7-03 and P7-04

If P7-03 and P7-04 parameters need to be displayed when running, **set the corresponding position to 1, and change every four bits of binary numbers into one hexadecimal number, and then enter the four hexadecimal numbers into F7-03 and F7-04.**

Running status display 1:

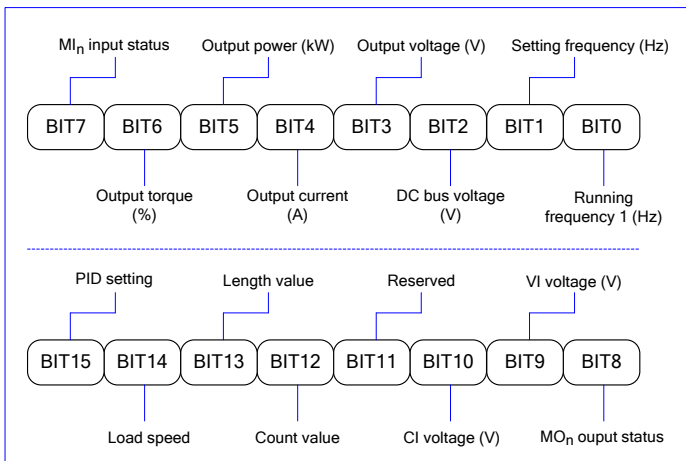

Running status display 2:

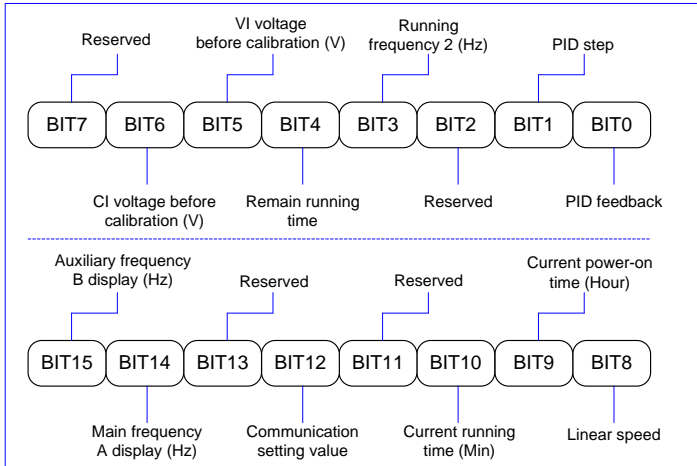

For example, if user wants to display **output voltage**, **DC bus voltage**, **setting frequency**, **running frequency**, **output current**, **output torque**, **VI voltage**, **CI voltage**, **output terminal status**, the value of each bit is as the following table:

BIT7	BIT6	BIT5	BIT4	BIT3	BIT2	BIT1	BIT0
0	0	1	1	1	1	1	1
3				F			
BIT15	BIT14	BIT13	BIT12	BIT11	BIT10	BIT9	BIT8
0	0	0	0	0	1	1	1
0				7			



The value of F7-03 is **073F**.

Chapter 5 Examples of Operation

5.1 Keypad start, stop, speed adjust by up, down button

Parameters setting: F0-02=0, F0-03=0, F0-23=1 (Digital setting frequency storage when stop);

Start, stop: press "RUN" button to make inverter run forward, press "REV/JOG" to make inverter run reverse, press "STOP/RESET" to stop the inverter

Speed adjusts: press  button to increase the frequency, press  button to decrease the frequency.

5.2 Keypad start, stop, speed adjust by keypad potentiometer

Parameters setting: factory default;

Start, stop: press "RUN" button to make inverter run forward, press "REV/JOG" to make inverter run reverse, press "STOP/RESET" to stop the inverter

Speed adjusts: turn the keypad potentiometer

5.3 Inverter start/stop by external signal, speed adjust by external potentiometer

Parameters setting: F0-02=1, F0-03=2, F5-01=02

Start, stop: "MI1--DCM" close, inverter run forward; "MI2--DCM" close, inverter run reverse, MI1, MI2 disconnect with DCM, inverter stop.

Speed adjusts: turn the external potentiometer (10V, VI, ACM)

5.4 Inverter start/stop by external signal, speed adjust by external 0~10V signal

Parameters setting: F0-02=1, F0-03=2, F5-01=02

Start, stop: "MI1--DCM" close, inverter run forward; "MI2--DCM" close, inverter run reverse, MI1, MI2 disconnect with DCM, inverter stop.

Speed adjusts: by changing the value of external voltage signal (VI, ACM)

5.5 Inverter start/stop by external signal, speed adjust by external 4~20mA signal

Parameters setting: F0-02=1, F0-03=2, F5-01=02

Start, stop: "MI1--DCM" close, inverter run forward; "MI2--DCM" close, inverter run reverse, MI1, MI2 disconnect with DCM, inverter stop.

Speed adjusts: by changing the value of external current signal (CI, ACM)

5.6 Increase or decrease the frequency by external digital input

(1) start/stop by keypad

Parameters setting: F0-02=1, F0-03=0, F5-00=06, F5-01=07

Start, stop: press "RUN" button to make inverter run forward, press "REV/JOG" to make inverter run reverse, press "STOP/RESET" to stop inverter.

Speed adjusts: “MI1--DCM” close, frequency increase; “MI2--DCM” close, frequency decrease.

(2) start/stop by external digital signal

Parameters setting: F0-02=1, F0-03=0, F5-00=06, F5-01=07, F5-02=01, F5-03=02

Start, stop: “MI3--DCM” close, inverter run forward; “MI4--DCM” close, inverter run reverse.

Speed adjusts: “MI1--DCM” close, frequency increase; “MI2--DCM” close, frequency decrease.

Note:

If the changed frequency needs to be stored after power off, please set P0-23=1.

5.7 Multi-step speed function

(1) start/stop by keypad

Parameters setting: F0-02=0, F0-03=6, F5-00=12, F5-01=13, F5-01=14 (FD-00~FD-15, 16 steps speed can be set)

Start, stop: press “RUN” button to make inverter run forward, press “REV/JOG” to make inverter run reverse, press “STOP/RESET” to stop inverter.

Speed adjusts: by different combinations of MI input (shown as below list).

(2) start/stop by external digital signal

Parameters setting: F0-02=1, F0-03=6, F5-00=12, F5-01=13, F5-02=14 (FD-00~FD-15, 16 steps speed can be set), F5-03=1, F5-04=2

Start, stop: “MI4--DCM” close, inverter run forward; “MI5--DCM” close, inverter run reverse.

Speed adjusts: by different combinations of MI input (shown as below list).

※ **Different combination means different speeds:**

K4	K3	K2	K1	Command setting	Corresponding parameter
OFF	OFF	OFF	OFF	Multi-step command 0	FD-00
OFF	OFF	OFF	ON	Multi-step command 1	FD-01
OFF	OFF	ON	OFF	Multi-step command 2	FD-02
OFF	OFF	ON	ON	Multi-step command 3	FD-03
OFF	ON	OFF	OFF	Multi-step command 4	FD-04
OFF	ON	OFF	ON	Multi-step command 5	FD-05
OFF	ON	ON	OFF	Multi-step command 6	FD-06
OFF	ON	ON	ON	Multi-step command 7	FD-07
ON	OFF	OFF	OFF	Multi-step command 8	FD-08
ON	OFF	OFF	ON	Multi-step command 9	FD-09
ON	OFF	ON	OFF	Multi-step command 10	FD-10
ON	OFF	ON	ON	Multi-step command 11	FD-11

ON	ON	OFF	OFF	Multi-step command 12	FD-12
ON	ON	OFF	ON	Multi-step command 13	FD-13
ON	ON	ON	OFF	Multi-step command 14	FD-14
ON	ON	ON	ON	Multi-step command 15	FD-15

5.8 Terminal command mode

F5-11=0: Two-line running mode 1:

This is the most common mode. The forward/reverse rotation of the motor is decided by the commands of FWD and REV terminals.

Terminal	Setting value	Description
MI _x	1	Forward running (FWD)
MI _y	2	Reverse running (REV)

K1	K2	Run command
OFF	OFF	Stop
OFF	ON	Reverse
ON	OFF	Forward
ON	ON	Stop

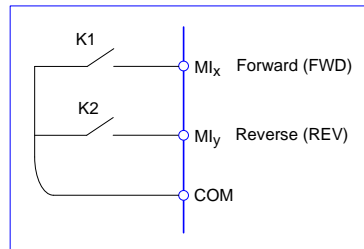

F5-11=1: Two-line running mode 2:

When this mode is adopted, REV is enabled terminal. The direction is determined by the status of FWD.

Terminal	Terminal	Description
MI _x	1	Run enable
MI _y	2	Forward / Reverse run control

K1	K2	Run command
OFF	OFF	Stop
OFF	ON	Stop
ON	OFF	Forward
ON	ON	Reverse

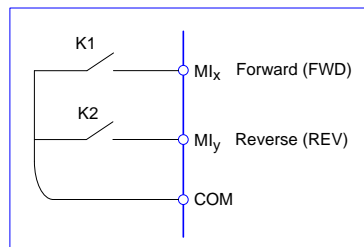

F5-11=2: Three-line running mode 1:

In this mode, MI_n is enabled terminal, and the direction is controlled by FWD and REV respectively. However, the pulse is enabled through disconnecting the signal of MI_n terminal when the inverter stops.

Terminal	Setting value	Description
MI _x	1	Forward running (FWD)
MI _y	2	Reverse running (REV)
MI _n	3	Three-line running control

To make the inverter run, users must close MI_n terminal firstly. It can achieve the motor forward or reverse control via pulse rising of MI_x or MI_y.

It can achieve the inverter stop via cutting off MI_n terminal signal. MI_x, MI_y, MI_n are MI1~MI6, the valid input of MI_x (MI_y) is pulses signal, and the valid input of MI_n is level signal.

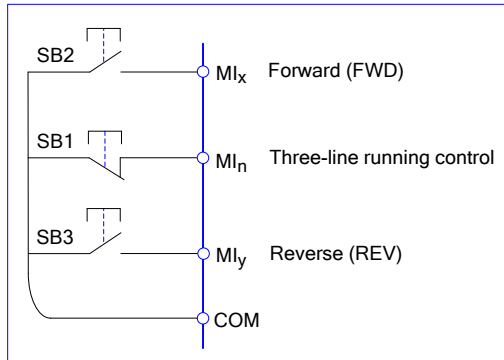

- SB1: Stop button
- SB2: Forward rotation button
- SB3: Reverse rotation button

F5-11=3: Three-line running mode 2:

In this mode, MI_N is enabled terminal, and the running command is given by FWD, while the direction is determined by the status of REV. Stop command is performed through disconnecting the MI_N signal.

Terminal	Setting value	Description
MI _x	1	Run enable
MI _y	2	Forward / Reverse run\ control
MI _n	3	Three-line running control

K	Running direction
OFF	Forward
ON	Reverse

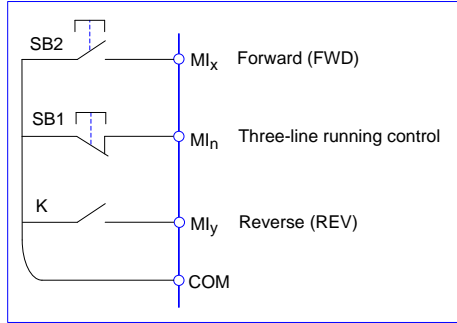

5.9 PID function

※ It mainly been applied on the applications of constant water supply, air-compressor.

(1) General applications

- ① Keypad set frequency (F9-01, 100% means maximum measure range)
- ② PID given source (F9-00=0, from keypad)
- ③ PID feedback source (P9-02=0 or P9-02=1)
- ④ PID action as positive (P9-03=0)

(2) Other related parameters

- ① Start/stop can be changed as keypad control or external signal control (F0-01-0 or 1)
- ② P9-01 is to set the percentage of pressure sensor's measure range.
- ③ Remote pressure meter wiring connection: 10V, VI, ACM
- ④ Pressure sensor wiring connection: 10V, CI and short connect ACM, DCM.

Chapter 6 Function Parameter List

The detailed functional parameters are listed in below table.

The instruction of the symbols in function parameter list is as following:

“○” Means the parameter can be modified at stop and running status.

“◎” Means the parameter cannot be modified at the running status.

“●” Means the parameter is the real detection value which cannot be modified.

6.1 Basic Function Parameters List

Function code	Name	Detailed instruction	Factory default	Modify
F0 Group: Basic Function				
F0-00	Inverter model	1: G model (constant torque load model) 2: P model (fan and pump load model) Note: If customer want to use in P model, just use it directly, no need to change any parameter.	1	●
F0-01	Control mode	0: Sensorless Vector Control (SVC) 1: Reserved 2: V/F control	2	◎
F0-02	Running command source	0: Keypad 1: Terminal 2: Communication	0	◎
F0-03	Main frequency source A selection	0: Keypad (F0-08, UP and DOWN Adjustable, non-recorded after power off) 1: Keypad potentiometer 2: VI (0~10V) 3: CI (0~10V / 4~20mA) 4: Reserved 5: Reserved 6: Multi-step speed 7: Simple PLC 8: PID 9: Communication (Modbus)	1	◎
F0-04	Auxiliary frequency source B selection	Same as F0-03	0	◎

Function code	Name	Detailed instruction	Factory default	Modify
F0-05	Reference of Frequency source B	0: Relative to maximum frequency 1: Relative to frequency source A	0	<input type="radio"/>
F0-06	Range of Auxiliary Frequency source B	0%~150%	100%	<input type="radio"/>
F0-07	Frequency source selection	Units place: frequency source selection 0: Main frequency source A 1: Calculation result of frequency A and B (determined by tens place) 2: Switching between A and B 3: Switching between A and calculation result 4: Switching between B and calculation result Tens place: calculation relationship between frequency A and B 0: A + B 1: A - B 2: Max (A, B) 3: Min (A, B)	00	<input type="radio"/>
F0-08	Keypad reference frequency	0.00Hz ~ maximum frequency (F0-10)	50.00Hz	<input type="radio"/>
F0-09	Running direction selection	0: Same direction 1: Reverse direction	0	<input type="radio"/>
F0-10	Maximum frequency	50.00Hz ~ 600.00Hz	50.00Hz	<input checked="" type="radio"/>
F0-11	Frequency source of upper limit	0: F0-12 1: VI 2: CI 3: Reserved 4: Reserved 5: Communication	0	<input checked="" type="radio"/>
F0-12	Frequency upper limit	F0-14 (frequency lower limit) ~ F0-10 (max. frequency)	50.00Hz	<input type="radio"/>
F0-13	Frequency upper limit offset	0.00Hz ~ F0-10 (max. frequency)	0.00Hz	<input type="radio"/>
F0-14	Frequency lower limit	0.00Hz ~ F0-12 (frequency upper limit)	0.00Hz	<input type="radio"/>
F0-15	Carrier frequency	0.5kHz ~ 16.0kHz	Model depend	<input type="radio"/>
F0-16	Carrier frequency adjusting according to temperature	0: No 1: Yes	1	<input type="radio"/>
F0-17	Acceleration time 1	0.00s ~ 65000s	Model	<input type="radio"/>

Function code	Name	Detailed instruction	Factory default	Modify
			depend	
F0-18	Deceleration time 1	0.00s ~ 65000s	Model depend	○
F0-19	ACC/DEC time unit	0: 1s 1: 0.1s 2: 0.01s	1	◎
F0-20	Reserved			
F0-21	Auxiliary frequency source offset frequency when combination	0.00Hz ~ F0-10 (max. frequency)	0.00Hz	○
F0-22	Frequency command resolution	1: 0.1Hz 2: 0.01Hz	2	◎
F0-23	Digital setting frequency storage selection when stop	0: Not store 1: store	1	○
F0-24	ACC/DEC time reference frequency	0: F0-10 (max. frequency) 1: Setting frequency 2: 100Hz	0	◎
F0-25	Running frequency command UP/DOWN reference	0: Running frequency 1: Setting frequency	0	◎
F0-26	Command source combination with frequency source	Units place: Operation keypad command combine with frequency source 0: No combination 1: Keypad Potentiometer 2: VI 3: CI 4: Reserved 5: Reserved 6: Multi-step speed 7: Simple PLC 8: PID 9: Communication Tens place: Terminal command combine with frequency source Hundreds place: Communication command combine with frequency source Thousands place: Auto running combine with frequency source	000	○
F0-27	Parameters initialization	0: No action	0	◎

Function code	Name	Detailed instruction	Factory default	Modify
		1: Initialize basic parameters (F0 and F1 groups) 2: Clear the record 3: Initialized completely		
F1 Group: Start and Stop control				
F1-00	Start mode	0: Direct start 1: Speed tracking and restart 2: Pre-excitation start	0	○
F1-01	Speed tracking mode	0: Begin from stop frequency 1: Begin from zero speed 2: Begin from maximum frequency	0	◎
F1-02	Speed tracking speed	1 ~ 100	20	○
F1-03	Start frequency	0.00Hz ~ 10.00Hz	0.00Hz	○
F1-04	Start frequency holding time	0.0s ~ 100.0s	0.0s	◎
F1-05	DC braking current before start/pre-excitation current	0% ~ 100%	0%	◎
F1-06	DC braking time before start/pre-excitation time	0.0s ~ 100.0s	0.0s	◎
F1-07	ACC/DEC mode	0: Linear ACC/DEC 1: S-curve ACC/DEC A (Applications which require start & stop smoothly, such as elevator and conveyor belt.) 2: S-curve ACC/DEC B (Suitable for the applications that the high speed area above rated frequency needs fast ACC/DEC.)	0	◎
F1-08	Time of S curve's start part	0.0% ~ (100.0% ~ F1-09)	30.0%	◎
F1-09	Time of S curve's end part	0.0% ~ (100.0% ~ F1-08)	30.0%	◎
F1-10	Stop mode	0: Deceleration to stop 1: Coast to stop	0	○
F1-11	DC braking start frequency while stopping	0.00Hz ~ F0-10 (max. frequency)	0.00Hz	○
F1-12	DC braking delay time while stopping	0.0s ~ 100.0s	0.0s	○
F1-13	DC braking current while stopping	0% ~ 100%	0%	○

Function code	Name	Detailed instruction	Factory default	Modify
F1-14	DC braking time while stopping	0.0s ~ 100.0s	0.0s	<input type="radio"/>
F1-15	Braking usage ratio	0% ~ 100%	100%	<input type="radio"/>
F2 Group: Motor Parameters				
F2-00	Motor type	0: Common asynchronous motor 1: Variable frequency asynchronous motor	0	<input type="radio"/>
F2-01	Motor rated power	0.1kW ~ 1000.0kW	Model depend	<input type="radio"/>
F2-02	Motor rated voltage	1V ~ 2000V	Model depend	<input type="radio"/>
F2-03	Motor rated current	0.01A ~ 655.35A (Inverter power ≤ 55kW) 0.1A ~ 6553.5A (Inverter power > 55kW)	Model depend	<input type="radio"/>
F2-04	Motor rated frequency	0.00Hz ~ F0-10 (max. frequency)	Model depend	<input type="radio"/>
F2-05	Motor rated speed	1 ~ 65535RPM	Model depend	<input type="radio"/>
F2-06	Motor stator resistance	0.001Ω ~ 65.535Ω (Inverter power ≤ 55kW) 0.0001Ω ~ 6.5535Ω (Inverter power > 55kW)	Motor parameter	<input type="radio"/>
F2-07	Motor rotor resistance	0.001Ω ~ 65.535Ω (Inverter power ≤ 55kW) 0.0001Ω ~ 6.5535Ω (Inverter power > 55kW)	Motor parameter	<input type="radio"/>
F2-08	Motor leakage inductance	0.01mH ~ 655.35mH (Inverter power ≤ 55kW) 0.001mH ~ 65.535mH (Inverter power > 55kW)	Motor parameter	<input type="radio"/>
F2-09	Motor mutual inductance	0.01mH ~ 655.35mH (Inverter power ≤ 55kW) 0.001mH ~ 65.535mH (Inverter power > 55kW)	Motor parameter	<input type="radio"/>
F2-10	Motor no-load current	0.01A ~ F2-03 (rated current) (Inverter power ≤ 55kW) 0.1A ~ F2-03 (rated current) (Inverter power > 55kW)	Motor parameter	<input type="radio"/>
F2-11	Parameters auto-tuning	0: No action 1: Static auto-tuning (motor with load)	0	<input type="radio"/>

Function code	Name	Detailed instruction	Factory default	Modify
		2: Rotation auto-tuning (motor without load)		
F3 Group: Vector Control Parameters				
F3-00	Speed loop proportional gain 1	1 ~ 100	30	○
F3-01	Speed loop integration time 1	0.01s ~ 10.00s	0.50s	○
F3-02	Low switching frequency	0.00 ~ F3-05	5.00Hz	○
F3-03	Speed loop proportional gain 2	1 ~ 100	20	○
F3-04	Speed loop integration time 2	0.01s ~ 10.00s	1.00s	○
F3-05	High switching frequency	F3-02 ~ F0-10 (max. frequency)	10.00Hz	○
F3-06	Vector control slip compensation coefficient	50% ~ 200%	100%	○
F3-07	Speed loop filter time	0.000s ~ 0.100s	0.000s	○
F3-08	Vector control over excitation gain	0 ~ 200	64	○
F3-09	Torque upper limit source selection in speed control mode	0: F3-10 1: VI 2: CI 3: Reserved 4: Reserved 5: Communication 6: Min (VI, CI) 7: Max (VI, CI) Full scale of 1-7 selection corresponds to F3-10	0	○
F3-10	Torque upper limit digital setting	0.0% ~ 200.0%	150.0%	○
F3-11	Reserved			○
F3-12	Reserved			○
F3-13	Excitation regulation proportional gain	0~60000	2000	○
F3-14	Excitation regulation integral gain	0~60000	1300	○
F3-15	Torque regulation proportional gain	0~60000	2000	○

Function code	Name	Detailed instruction	Factory default	Modify
F3-16	Torque regulation integral gain	0~60000	1300	<input type="radio"/>
F3-17	Speed loop integral property	Integral separation 0: Invalid 1: Valid	0	<input type="radio"/>
F4 Group: V/f Control Parameters				
F4-00	V/f curve setting	0: Linear 1: Multiple-points 2: Square 3: 1.2th power 4: 1.4th power 6: 1.6th power 8: 1.8th power 9: Reserved 10: V/f separate completely 11: V/f separate partially	0	<input checked="" type="radio"/>
F4-01	Torque boost	0.0: auto 0.1% ~ 30.0%	Model depend	<input type="radio"/>
F4-02	Torque boost cutoff frequency	0.00Hz ~ F0-10 (max. frequency)	50.00Hz	<input checked="" type="radio"/>
F4-03	V/f frequency point 1	0.00Hz ~ F4-05	0.00Hz	<input checked="" type="radio"/>
F4-04	V/f voltage point 1	0.0% ~ 100.0%	0.0%	<input checked="" type="radio"/>
F4-05	V/f frequency point 2	F4-03 ~ F4-07	0.00Hz	<input checked="" type="radio"/>
F4-06	V/f voltage point 2	0.0% ~ 100.0%	0.0%	<input checked="" type="radio"/>
F4-07	V/f frequency point 3	F4-05 ~ F2-04 (motor rated frequency)	0.00Hz	<input checked="" type="radio"/>
F4-08	V/f voltage point 3	0.0% ~ 100.0%	0.0%	<input checked="" type="radio"/>
F4-09	V/f slip compensation gain	0.0% ~ 200.0%	0.0%	<input type="radio"/>
F4-10	V/f over excitation gain	0 ~ 200	64	<input type="radio"/>
F4-11	V/f oscillation suppression gain	0 ~ 100	Model depend	<input type="radio"/>
F4-12	Reserved			
F4-13	Voltage source of V/f separation	0: Digital setting (F4-14) 1: VI 2: CI 3: Reserved 4: Reserved 5: Multi-step speed 6: Simple PLC	0	<input type="radio"/>

Function code	Name	Detailed instruction	Factory default	Modify
		7: PID 8: Communication Note: 100% corresponds to motor rated voltage		
F4-14	Digital setting of V/f separation	0V~F2-02 (Motor rated voltage)	0V	○
F4-15	Voltage rise up time of V/f separation	0.0s~1000.0s Note: means voltage rise up time from 0 to motor rated voltage	0.0s	○
F5 Group: Input Terminals				
F5-00	MI1 terminal function	0: No function	1	◎
F5-01	MI2 terminal function	1: Forward (FWD)	2	◎
F5-02	MI3 terminal function	2: Reverse (REV)	0	◎
F5-03	MI4 terminal function	3: Three-line running control	0	◎
		4: Forward Jog (FJOG)	0	◎
		5: Reverse Jog (RJOG)	0	◎
		6: Terminal UP	0	◎
		7: Terminal DOWN	0	◎
		8: Coast to stop		
		9: Fault reset (RESET)		
		10: Pause running		
		11: External fault (normal open) input		
		12: Multi-step speed terminal 1		
		13: Multi-step speed terminal 2		
		14: Multi-step speed terminal 3		
		15: Multi-step speed terminal 4		
		16: ACC/DEC selection terminal 1		
		17: ACC/DEC selection terminal 2		
F5-04	MI5 terminal function	18: Main frequency source switching	0	◎
		19: UP and DOWN setting clear (terminal and keypad)		
		20: Running command switching terminal		
		21: ACC/DEC invalid		
		22: PID Pause		
		23: PLC status reset		
		24: Wobble frequency pause		
		25: Counter input		
		26: Counter reset		
		27: Length count input		
		28: Length reset		
		29: Torque control invalid		

Function code	Name	Detailed instruction	Factory default	Modify
		30~31: Reserved 32: DC braking command 33: External fault (normal closed) input 34: Frequency modification enabled 35: PID action direction reverse 36: External stop terminal 1 37: Control command switching terminal 2 38: PID integration stop 39: Switch frequency source A to preset frequency 40: Switch frequency source B to preset frequency 41~42: Reserved 43: PID parameter switching 44~45: Reserved 46: Speed control / torque control switching 47: Emergency stop 48: External stop terminal 2 49: Deceleration DC braking 50: The running time reset		
F5-05 ~ F5-09	Reserved			
F5-10	MI terminals filter time	0.000s ~ 1.000s	0.010s	○
F5-11	Terminal command mode	0: Two-line mode 1 1: Two-line mode 2 2: Three-line mode 1 3: Three-line mode 2	0	◎
F5-12	UP/DOWN change rate	0.001Hz/s ~ 65.535Hz/s	1.00Hz/s	○
F5-13	VI minimum input	0.00V ~ 10.00V	0.00V	○
F5-14	VI minimum input corresponding setting	-100.0% ~ +100.0%	0.0%	○
F5-15	VI maximum input	0.00 ~ 10.00V	10.00V	○
F5-16	VI maximum input corresponding setting	-100.0% ~ +100.0%	100.0%	○
F5-17	VI input filter time	0.00s ~ 10.00s	0.10s	○

Function code	Name	Detailed instruction	Factory default	Modify
F5-18	CI minimum input	0.00V ~ 10.00V	0.00V	○
F5-19	CI minimum input corresponding setting	-100.0% ~ +100.0%	0.0%	○
F5-20	CI maximum input	0.00~ 10.00V	10.00V	○
F5-21	CI maximum input corresponding setting	-100.0% ~ +100.0%	100.0%	○
F5-22	CI input filter time	0.00s ~ 10.00s	0.10s	○
F5-23 ~ F5-56	Reserved			
F5-57	MI1 delay time	0.0s ~ 3600.0s	0.0s	◎
F5-58	MI2 delay time	0.0s ~ 3600.0s	0.0s	◎
F5-59	MI3 delay time	0.0s ~ 3600.0s	0.0s	◎
F5-60	MI terminals valid mode selection	0: Active-high level signal 1: Active-low level signal Units place: MI1 Tens place: MI2 Hundreds place: MI3 Thousands place: MI4 Ten thousands place: MI5	00000	◎
F5-61	Reserved			
F6 Group: Output Terminal				
F6-00	Reserved			
F6-01	MO1 output function selection (open collector output)	0: No output 1: Inverter is running 2: Fault output (fault stop) 3: FDT1 output	0	○
F6-02	Relay 1 output selection (TA, TB, TC)	4: Frequency arrival 5: Zero-speed running (no output when stop) 6: Motor overload pre-alarm	2	○
F6-03	Reserved	7: Inverter overload pre-alarm 8: Setting count value arrival 9: Designated count value arrival	0	
F6-04	Reserved	10: Length arrival 11: Simple PLC circulate running completed 12: Accumulated running time arrival	0	○
F6-05	Reserved	13: Frequency limiting 14: Torque limiting	0	○

Function code	Name	Detailed instruction	Factory default	Modify
		15: Ready for running 16: VI>CI 17: Frequency upper limit arrival 18: Frequency lower limit arrival 19: Under voltage status output 20: Communication setting 21: Position fixed (reserved) 22: Position approach (reserved) 23: Zero-speed running 2 (output when stop) 24: Accumulated power-on time arrival 25: FDT2 output 26: Frequency 1 arrival output 27: Frequency 2 arrival output 28: Current 1 arrival output 29: Current 2 arrival output 30: Timing arrival output 31: VI input over limit 32: Off load 33: Reverse running 34: Zero-current status 35: Module temperature arrival 36: Output current over limit 37: Lower limit frequency arrival (output when stop) 38: Warning output (keep running) 39: Motor over temperature pre-alarm 40: This running time arrival		
F6-06	Reserved	0: Running frequency		
F6-07	AM output function selection	1: Setting frequency	0	○
F6-08	Reserved	2: Output current 3: Output torque 4: Output power 5: Output voltage 6: Reserved 7: VI 8: CI 9: Reserved 10: Length 11: Count value 12: Communication 13: Motor speed 14: Output current (100.0%	1	○

Function code	Name	Detailed instruction	Factory default	Modify
		corresponds to 1000.0A) 15: Output voltage (100.0% corresponds to 1000.0V) 16: Reserved		
F6-09	Reserved			
F6-10	AM offset coefficient	-100.0% ~ +100.0%	0.0%	○
F6-11	AM gain	-10.00 ~ +10.00	1.00	○
F6-12 ~ F6-17	Reserved			
F6-18	Relay 1 output delay time	0.0s ~ 3600.0s	0.0s	○
F6-19	Reserved			
F6-20	MO1 output delay time	0.0s ~ 3600.0s	0.0s	○
F6-21	Reserved			
F6-22	Output terminal valid status selection	0: Positive logic 1: Negative logic Units place: MO1 Tens place: Relay 1 Hundreds place: Reserved Thousands place: Reserved Ten thousands place: Reserved	00000	○
F7 Group: Keypad and Display				
F7-00	User password	0 ~ 65535	0	○
F7-01	REV/JOG function selection	0: Reverse run 1: Switching between keypad command and remote command (terminal command or communication command) 2: FDW/REV Switching 3: Forward Jog 4: Reverse Jog	0	◎
F7-02	STOP/RESET function selection	0: Valid when keypad control 1: Always valid	1	○
F7-03	Running status display 1	0000 ~ FFFF Bit00: Running frequency 1 (Hz) Bit01: Setting frequency (Hz) Bit02: DC Bus voltage (V) Bit03: Output voltage (V) Bit04: Output current (A)	001F	○

Function code	Name	Detailed instruction	Factory default	Modify
		Bit05: Output power (kW) Bit06: Output torque (%) Bit07: MI input status Bit08: MO output status Bit09: VI voltage (V) Bit10: CI voltage (V) Bit11: Reserved Bit12: Count value Bit13: Length value Bit14: Load speed display Bit15: PID setting		
F7-04	Running status display 2	0000 ~ FFFF Bit00: PID feedback Bit01: PLC step Bit02: Reserved Bit03: Running frequency 2 (Hz) Bit04: Remain running time Bit05: VI voltage before calibration (V) Bit06: CI voltage before calibration (V) Bit07: Reserved Bit08: Linear speed Bit09: Current power-on time (Hour) Bit10: Current running time (Min) Bit11: Reserved Bit12: Communication setting value Bit13: Reserved Bit14: Main frequency A display (Hz) Bit15: Auxiliary frequency B display (Hz)	0000	○
F7-05	Stop status display	0000 ~ FFFF Bit00: Setting frequency (Hz) Bit01: DC Bus voltage (V) Bit02: MI input status Bit03: MO output status Bit04: VI voltage(V) Bit05: CI voltage(V) Bit06: Reserved Bit07: Count value Bit08: Length value Bit09: PLC step Bit10: Load speed Bit11: PID setting Bit12: Reserved	0033	○

Function code	Name	Detailed instruction	Factory default	Modify
F7-06	Load speed display coefficient	0.0001 ~ 6.5000 (1.0000 means 500RPM, 3.0000 means 1500RPM)	3.0000	<input type="radio"/>
F7-07	IGBT module temperature	0.0°C~ 100.0°C	-	<input checked="" type="radio"/>
F7-08	The second LED display values	00: Running frequency 1 (Hz) 01: Setting frequency (Hz) 02: DC Bus voltage (V) 03: Output voltage (V) 04: Output current (A) 05: Output power (kW) 06: Output torque (%) 07: MI input status 08: MO output status 09: VI voltage (V) 10: CI voltage (V) 11: Inverter temperature 12: Count value 13: Length value 14: Load speed display 15: PID setting 16: PLC feedback 17: PID step 19: Communication setting frequency 19: Main frequency A display (Hz) 20: Auxiliary frequency B display (Hz) 21: Current power-on time (Hour) 22: Current running time (Min) 23: Accumulated running time 24: Remain running time	04	<input type="radio"/>
F7-09	Accumulated running time	0h ~ 65535h	-	<input checked="" type="radio"/>
F7-10	Model No.	-	-	<input checked="" type="radio"/>
F7-11	Software version No.	-	-	<input checked="" type="radio"/>
F7-12	Load speed display decimal place	0: 0 decimal place 1: 1 decimal place 2: 2 decimal places 3: 3 decimal places	1	<input type="radio"/>
F7-13	Accumulated Power-on time	0h ~ 65535h	-	<input checked="" type="radio"/>

Function code	Name	Detailed instruction	Factory default	Modify
F7-14	Accumulated power consumption	0kWh ~ 65535kWh	-	●
F7-15	Function codes modification authority	0: Enable 1: Disable	0	○
F8 Group: Enhanced Functions				
F8-00	Jog running frequency	0.00Hz ~ F0-10 (max. frequency)	2.00Hz	○
F8-01	Jog acceleration time	0.0s ~ 6500.0s	20.0s	○
F8-02	Jog deceleration time	0.0s ~ 6500.0s	20.0s	○
F8-03	Acceleration time 2	0.0s ~ 6500.0s	Model depend	○
F8-04	Deceleration time 2	0.0s ~ 6500.0s	Model depend	○
F8-05	Acceleration time 3	0.0s ~ 6500.0s	Model depend	○
F8-06	Deceleration time 3	0.0s ~ 6500.0s	Model depend	○
F8-07	Acceleration time 4	0.0s ~ 6500.0s	Model depend	○
F8-08	Deceleration time 4	0.0s ~ 6500.0s	Model depend	○
F8-09	Jump frequency 1	0.00Hz ~ F0-10 (maximum frequency)	0.00Hz	○
F8-10	Jump frequency 2	0.00Hz ~ F0-10 (maximum frequency)	0.00Hz	○
F8-11	Jump frequency amplitude	0.00Hz ~ F0-10 (maximum frequency)	0.01Hz	○
F8-12	FWD/REV dead time	0.0s ~ 3000.0s	0.0s	○
F8-13	Reverse control	0: Enable 1: Disable	0	○
F8-14	Action when setting frequency lower than frequency lower limit	0: Running at frequency lower limit (F0-14) 1: Stop 2: Zero-speed running	0	○
F8-15	Droop control	0.00Hz ~ 10.00Hz	0.00Hz	○
F8-16	Accumulated power-on arrival time	0h ~ 65000h	0h	○
F8-17	Accumulated running arrival time	0h ~ 65000h	0h	○
F8-18	Power-on running command valid protection	0: No protection (Auto restart after power-on)	0	○

Function code	Name	Detailed instruction	Factory default	Modify
	selection	1: Protection (Cannot restart after power-on) ※ This function is only valid under terminal control mode (F0-02=1).		
F8-19	Frequency detection value (FDT1)	0.00Hz ~ F0-10 (maximum frequency)	50.00Hz	○
F8-20	Frequency detection lagging value (FDT1)	0.0% ~ 100.0% (F8-19)	5.0%	○
F8-21	Frequency arrival detection amplitude	0.0% ~ 100.0% (maximum frequency)	0.0%	○
F8-22	Jump frequency control during ACC/DEC	0: Invalid 1: Valid	0	○
F8-25	Acceleration time 1 and acceleration time 2 switching frequency point	0.00Hz ~ F0-10 (maximum frequency)	0.00Hz	○
F8-26	Deceleration time 1 and deceleration time 2 switching frequency point	0.00Hz ~ F0-10 (maximum frequency)	0.00Hz	○
F8-27	Terminal jog priority	0: Invalid 1: Valid	0	○
F8-28	Frequency detection value (FDT2)	0.00Hz ~ F0-10 (maximum frequency)	50.00Hz	○
F8-29	Frequency detection lagging value (FDT2)	0.0% ~ 100.0% (F8-28)	5.0%	○
F8-30	Any arrival frequency detection value 1	0.00Hz ~ F0-10 (maximum frequency)	50.00Hz	○
F8-31	Any arrival frequency detection amplitude 1	0.0% ~ 100.0% (maximum frequency)	0.0%	○
F8-32	Any arrival frequency detection value 2	0.00Hz ~ F0-10 (maximum frequency)	50.00Hz	○
F8-33	Any arrival frequency detection amplitude 2	0.0% ~ 100.0% (maximum frequency)	0.0%	○
F8-34	Zero-current detection level	0.0% ~ 300.0% 100.0% corresponds to motor rated current	5.0%	○
F8-35	Zero-current detection delay time	0.01s ~ 600.00s	0.10s	○
F8-36	Output current over limit value	0.0% (No detection) 0.1% ~ 300.0% (motor rated current)	200.0%	○
F8-37	Output current over limit detection delay time	0.00s ~ 600.00s	0.00s	○

Function code	Name	Detailed instruction	Factory default	Modify
F8-38	Any arrival current 1	0.0% ~ 300.0% (motor rated current)	100.0%	<input type="radio"/>
F8-39	Any arrival current 1 amplitude	0.0% ~ 300.0% (motor rated current)	0.0%	<input type="radio"/>
F8-40	Any arrival current 2	0.0% ~ 300.0% (motor rated current)	100.0%	<input type="radio"/>
F8-41	Any arrival current 2 amplitude	0.0% ~ 300.0% (motor rated current)	0.0%	<input type="radio"/>
F8-42	Timing function selection	0: Invalid 1: Valid	0	<input type="radio"/>
F8-43	Timing running duration source selection	0:F8-44 1:VI 2:CI 3:Reserved Analog input scale corresponds to F8-44	0	<input type="radio"/>
F8-44	Timing running duration	0.0Min ~ 6500.0Min	0.0Min	<input type="radio"/>
F8-45	VI input voltage protection lower limit	0.00V ~ F8-46	3.10V	<input type="radio"/>
F8-46	VI input voltage protection upper limit	F8-45 ~ 10.00V	6.80V	<input type="radio"/>
F8-47	Module temperature arrival	0°C ~ 100°C	75°C	<input type="radio"/>
F8-48	Reserved			
F8-49	Wake up frequency	F8-51 (Dormancy frequency) ~ F0-10 (max. frequency)	0.00Hz	<input type="radio"/>
F8-50	Wake up delay time	0.0s ~ 6500.0s	0.0s	<input type="radio"/>
F8-51	Dormancy frequency	0.00Hz ~ F8-49 (Wake up frequency)	0.00Hz	<input type="radio"/>
F8-52	Dormancy delay time	0.0s ~ 6500.0s	0.0s	<input type="radio"/>
F8-53	Running arrival time setting	0.0Min ~ 6500.0Min	0.0Min	<input type="radio"/>
F9 Group: PID Function				
F9-00	PID given source	0: F9-01 1: VI 2: CI 3: Reserved 4: Reserved 5: Communication 6: Multi-step command	0	<input type="radio"/>

Function code	Name	Detailed instruction	Factory default	Modify
F9-01	PID given through keypad	0.0%~100% (percentage of sensor measure range)	50.0%	<input type="radio"/>
F9-02	PID feedback source	0: VI 1: CI 2: Reserved 3: VI-CI 4: Reserved 5: Communication 6: VI+CI 7: MAX (VI , CI) 8: MIN (VI , CI)	0	<input type="radio"/>
F9-03	PID action direction	0: Positive 1: Negative	0	<input type="radio"/>
F9-04	PID given feedback range	0~65535	1000	<input type="radio"/>
F9-05	Proportional gain Kp1	0.0 ~ 100.0	20.0	<input type="radio"/>
F9-06	Integration time Ti1	0.01s ~ 10.00s	2.00s	<input type="radio"/>
F9-07	Differential time Td1	0.000s ~ 10.000s	0.000s	<input type="radio"/>
F9-08	Cutoff frequency of PID reverse	0.00 ~ F0-10 (maximum frequency)	0.00Hz	<input type="radio"/>
F9-09	PID deviation limit	0.0% ~ 100.0%	0.0%	<input type="radio"/>
F9-10	PID differential amplitude	0.00% ~ 100.00%	0.10%	<input type="radio"/>
F9-11	PID given filter time	0.00 ~ 650.00s	0.00s	<input type="radio"/>
F9-12	PID feedback filter time	0.00 ~ 60.00s	0.00s	<input type="radio"/>
F9-13	PID output filter time	0.00 ~ 60.00s	0.00s	<input type="radio"/>
F9-14	Reserved			
F9-15	Proportional gain Kp2	0.0 ~ 100.0	20.0	<input type="radio"/>
F9-16	Integration time Ti2	0.01s ~ 10.00s	2.00s	<input type="radio"/>
F9-17	Differential time Td2	0.000s ~ 10.000s	0.000s	<input type="radio"/>
F9-18	PID parameter switching condition	0: No switching 1: Switching via MIn terminals 2: Automatic switching according to the deviation	0	<input type="radio"/>
F9-19	PID parameter switching deviation 1	0.0% ~F9-20	20.0%	<input type="radio"/>

Function code	Name	Detailed instruction	Factory default	Modify
F9-20	PID parameter switching deviation 2	F9-19 ~ 100.0%	80.0%	<input type="radio"/>
F9-21	PID initial value	0.0% ~ 100.0%	0.0%	<input type="radio"/>
F9-22	PID initial value holding time	0.00 ~ 650.00s	0.00s	<input type="radio"/>
F9-23	Forward maximum value between two output deviation	0.00% ~ 100.00%	1.00%	<input type="radio"/>
F9-24	Reverse maximum value between two output deviation	0.00% ~ 100.00%	1.00%	<input type="radio"/>
F9-25	PID integration attribute	Units place: Integration separate 0: Invalid 1: Valid Tens place: Stop integrating or not after output reach limit 0: Keep integrating 1: Stop integrating	00	<input type="radio"/>
F9-26	PID feedback lost detection value	0.0%: No judgment for feedback lost 0.1% ~ 100.0%	0.0%	<input type="radio"/>
F9-27	PID feedback lost detection time	0.0s ~ 20.0s	0.0s	<input type="radio"/>
F9-28	PID stop calculation	0: No calculation when stop 1: Calculation when stop	1	<input type="radio"/>
FA Group: Fault and Protection				
FA-00	Motor overload protection selection	0: Disable 1: Enable	1	<input type="radio"/>
FA-01	Motor overload protection gain	0.20 ~ 10.00	1.00	<input type="radio"/>
FA-02	Motor overload pre-alarm coefficient	50% ~ 100%	80%	<input type="radio"/>
FA-03	Stall over-voltage gain	0 ~ 100	Model depend	<input type="radio"/>
FA-04	Stall over-voltage point / Braking threshold	120% ~ 150%	135%	<input type="radio"/>
FA-05	Stall over current gain	0 ~ 100	30	<input type="radio"/>
FA-06	Stall over-current point	100% ~ 200%	170%	<input type="radio"/>
FA-07	Short-circuit to ground protection selection when power-on	0: Invalid 1: Valid	1	<input type="radio"/>

Function code	Name	Detailed instruction	Factory default	Modify
FA-08	Reserved			
FA-09	Fault auto-reset times	0 ~ 20	0	○
FA-10	MO output selection during fault auto-reset	0: No action 1: Action	0	○
FA-11	Fault auto-reset interval	0.1s ~ 100.0s	1.0s	○
FA-12	Reserved			
FA-13	Output phase failure protection selection	0: Disable 1: Enable	1	○
FA-14	The first fault type	0: No fault 1: Reserved	—	●
FA-15	The second fault type	2: Acc over current 3: Dec over current	—	●
FA-16	The third (latest) fault type	4: Over current in constant speed 5: Over voltage in Acc process 6: Over voltage in Dec process 7: Over voltage in constant speed 8: Buffer resistor overload 9: Under voltage 10: Inverter overload 11: Motor overload 12: Input side phase failure 13: Output side phase failure 14: IGBT Module overheat 15: External fault 16: Communication fault 17: Contactor fault 18: Current detection fault 19: Motor auto-tuning fault 20: Reserved 21: Parameter R/W fault 22: Inverter hardware fault 23: Motor short circuit to ground fault 24: Reserved 25: Reserved 26: Running time arrival 27: Reserved 28: Reserved 29: Power-on time arrival 30: Off load 31: PID feedback lost when running	—	●

Function code	Name	Detailed instruction	Factory default	Modify
		40: Fast current limiting over time 41: Switch the motor during running 42 ~ 51: Reserved		
FA-17	Frequency at the third (latest) fault	—	—	●
FA-18	Current at the third (latest) fault	—	—	●
FA-19	Bus voltage at the third (latest) fault	—	—	●
FA-20	Input terminal's status at the third (latest) fault	—	—	●
FA-21	Output terminal's status at the third (latest) fault	—	—	●
FA-22	Inverter status at the third (latest) fault	—	—	●
FA-23	Power-on time at the third (latest) fault	—	—	●
FA-24	Running time at the third (latest) fault	—	—	●
FA -25 ~ FA-26	Reserved			
FA-27	Frequency at the second fault	—	—	●
FA-28	Current at the second fault	—	—	●
FA-29	Bus voltage at the second fault	—	—	●
FA-30	Input terminal's status at the second fault	—	—	●
FA-31	Output terminal's status at the second fault	—	—	●
FA-32	Inverter status at the second fault	—	—	●
FA-33	Power-on time at the second fault	—	—	●
FA-34	Running time at the second fault	—	—	●
FA -35 ~ FA-36	Reserved			
FA-37	Frequency at the first fault	—	—	●
FA-38	Current at the first fault	—	—	●

Function code	Name	Detailed instruction	Factory default	Modify
FA-39	DC bus voltage at the first fault	—	—	●
FA-40	Input terminal's status at the first fault	—	—	●
FA-41	Output terminal's status at the first fault	—	—	●
FA-42	Inverter status at the first fault	—	—	●
FA-43	Power-on time at the first fault	—	—	●
FA-44	Running time at the first fault	—	—	●
FA-45 ~ FA-58	Reserved			
FA-59	Instantaneous power-off action selection	0: Invalid 1: Deceleration 2: Deceleration-to-stop	0	○
FA-60	Reserved			
FA-61	Recover judgment time when Instantaneous power-off	0.00s ~ 100.00s	0.50s	○
FA-62	Recover judgment voltage when Instantaneous power-off	60 ~ 100.0%	80.0%	○
FA-63	Off-load protection selection	0: Disable 1: Enable	0	○
FA-64	Off-load detection level	0.0 ~ 100.0%	10.0%	○
FA-65	Off-load detection time	0.0 ~ 60.0s	1.0s	○
FA-66 ~ FA-70	Reserved			
FB Group: Wobble Frequency, Fixed Length, Counting				
FB-00	Wobble frequency setting mode	0: Relative to center frequency 1: Relative to maximum frequency	0	○
FB-01	Wobble frequency amplitude	0.0% ~ 100.0%	0.0%	○
FB-02	Sudden Jump frequency amplitude	0.0% ~ 50.0%	0.0%	○
FB-03	Wobble frequency cycle	0.1s ~ 3000.0s	10.0s	○
FB-04	Triangular wave rise time coefficient	0.1% ~ 100.0%	50.0%	○

Function code	Name	Detailed instruction	Factory default	Modify
FB-05	Setting length	0m ~ 65535m	1000m	<input type="radio"/>
FB-06	Actual length	0m ~ 65535m	0m	<input type="radio"/>
FB-07	Number of pulses per meter	0.0 ~ 6553.5	100.0	<input type="radio"/>
FB-08	Setting count value	1 ~ 65535	1000	<input type="radio"/>
FB-09	Designated count value	1 ~ 65535	1000	<input type="radio"/>
FC Group: Communication Parameters				
FC-00	Baud rate	Unit place: Modbus 0: 300BPS 1: 600BPS 2: 1200BPS 3: 2400BPS 4: 4800BPS 5: 9600BPS 6: 19200BPS 7: 38400BPS 8: 57600BPS 9: 115200BPS Tens place: Reserved Hundred place: Reserved Thousand place: Reserved	6005	<input type="radio"/>
FC-01	Data format	0: No parity check (8-N-2) 1: Even parity check (8-E-1) 2: Odd parity check (8-O-1) 3: No parity check (8-N-1)	0	<input type="radio"/>
FC-02	Inverter address	1 ~ 249, 0 is broadcast address	1	<input type="radio"/>
FC-03	Communication delay time	0ms ~ 20ms	2ms	<input type="radio"/>
FC-04	Communication timeout time	0.0 (invalid) 0.1s ~ 60.0s	0.0	<input type="radio"/>
FC-05	Communication protocol selection	Unit place: Modbus 0: Non-standard MODBUS protocol 1: Standard MODBUS protocol Tens place: Reserved	31	<input type="radio"/>
FC-06	Communication read current resolution	0: 0.01A 1: 0.1A	0	<input type="radio"/>
FD Group: Multi-step Command and Simple PLC				
FD-00	Multi-step speed 0	-100.0% ~ 100.0%	0.0%	<input type="radio"/>

Function code	Name	Detailed instruction	Factory default	Modify
FD-01	Multi-step speed 1	-100.0% ~ 100.0%	0.0%	<input type="radio"/>
FD-02	Multi-step speed 2	-100.0% ~ 100.0%	0.0%	<input type="radio"/>
FD-03	Multi-step speed 3	-100.0% ~ 100.0%	0.0%	<input type="radio"/>
FD-04	Multi-step speed 4	-100.0% ~ 100.0%	0.0%	<input type="radio"/>
FD-05	Multi-step speed 5	-100.0% ~ 100.0%	0.0%	<input type="radio"/>
FD-06	Multi-step speed 6	-100.0% ~ 100.0%	0.0%	<input type="radio"/>
FD-07	Multi-step speed 7	-100.0% ~ 100.0%	0.0%	<input type="radio"/>
FD-08	Multi-step speed 8	-100.0% ~ 100.0%	0.0%	<input type="radio"/>
FD-09	Multi-step speed 9	-100.0% ~ 100.0%	0.0%	<input type="radio"/>
FD-10	Multi-step speed 10	-100.0% ~ 100.0%	0.0%	<input type="radio"/>
FD-11	Multi-step speed 11	-100.0% ~ 100.0%	0.0%	<input type="radio"/>
FD-12	Multi-step speed 12	-100.0% ~ 100.0%	0.0%	<input type="radio"/>
FD-13	Multi-step speed 13	-100.0% ~ 100.0%	0.0%	<input type="radio"/>
FD-14	Multi-step speed 14	-100.0% ~ 100.0%	0.0%	<input type="radio"/>
FD-15	Multi-step speed 15	-100.0% ~ 100.0%	0.0%	<input type="radio"/>
FD-16	Simple PLC running mode	0: Stop after one cycle 1: Keep last frequency after one cycle 2: Circular running	0	<input type="radio"/>
FD-17	Simple PLC status memory selection	Units place: Memory selection when power-off 0: Not memory 1: Memory Tens place: Memory selection when stop 0: Not memory 1: Memory	00	<input type="radio"/>
FD-18	0 th step running time	0.0s (h) ~ 6500.0s (h)	0.0s (h)	<input type="radio"/>
FD-19	0 th step ACC/DEC time selection	0 ~ 3	0	<input type="radio"/>
FD-20	1 st step running time	0.0s (h) ~ 6500.0s (h)	0.0s (h)	<input type="radio"/>
FD-21	1 st step ACC/DEC time selection	0 ~ 3	0	<input type="radio"/>

Function code	Name	Detailed instruction	Factory default	Modify
FD-22	2 nd step running time	0.0s (h) ~ 6500.0s (h)	0.0s (h)	<input type="radio"/>
FD-23	2 nd step ACC/DEC time selection	0 ~ 3	0	<input type="radio"/>
FD-24	3 rd step running time	0.0s (h) ~ 6500.0s (h)	0.0s (h)	<input type="radio"/>
FD-25	3 rd step ACC/DEC time selection	0 ~ 3	0	<input type="radio"/>
FD-26	4 th step running time	0.0s (h) ~ 6500.0s (h)	0.0s (h)	<input type="radio"/>
FD-27	4 th step ACC/DEC time selection	0 ~ 3	0	<input type="radio"/>
FD-28	5 th step running time	0.0s (h) ~ 6500.0s (h)	0.0s (h)	<input type="radio"/>
FD-29	5 th step ACC/DEC time selection	0 ~ 3	0	<input type="radio"/>
FD-30	6 th step running time	0.0s (h) ~ 6500.0s (h)	0.0s (h)	<input type="radio"/>
FD-31	6 th step ACC/DEC time selection	0 ~ 3	0	<input type="radio"/>
FD-32	7 th step running time	0.0s (h) ~ 6500.0s (h)	0.0s (h)	<input type="radio"/>
FD-33	7 th step ACC/DEC time selection	0 ~ 3	0	<input type="radio"/>
FD-34	8 th step running time	0.0s (h) ~ 6500.0s (h)	0.0s (h)	<input type="radio"/>
FD-35	8 th step ACC/DEC time selection	0 ~ 3	0	<input type="radio"/>
FD-36	9 th step running time	0.0s (h) ~ 6500.0s (h)	0.0s (h)	<input type="radio"/>
FD-37	9 th step ACC/DEC time selection	0 ~ 3	0	<input type="radio"/>
FD-38	10 th step running time	0.0s (h) ~ 6500.0s (h)	0.0s (h)	<input type="radio"/>
FD-39	10 th step ACC/DEC time selection	0 ~ 3	0	<input type="radio"/>
FD-40	11 th step running time	0.0s (h) ~ 6500.0s (h)	0.0s (h)	<input type="radio"/>
FD-41	11 th step ACC/DEC time selection	0 ~ 3	0	<input type="radio"/>
FD-42	12 th step running time	0.0s (h) ~ 6500.0s (h)	0.0s (h)	<input type="radio"/>
FD-43	12 th step ACC/DEC time selection	0 ~ 3	0	<input type="radio"/>
FD-44	13 th step running time	0.0s (h) ~ 6500.0s (h)	0.0s (h)	<input type="radio"/>

Function code	Name	Detailed instruction	Factory default	Modify
FD-45	13 th step ACC/DEC time selection	0 ~ 3	0	○
FD-46	14 th step running time	0.0s (h) ~ 6500.0s (h)	0.0s (h)	○
FD-47	14 th step ACC/DEC time selection	0 ~ 3	0	○
FD-48	15 th step running time	0.0s (h) ~ 6500.0s (h)	0.0s (h)	○
FD-49	15 th step ACC/DEC time selection	0 ~ 3	0	○
FD-50	Timing unit (Simple PLC mode)	0: s (second) 1: h (hour)	0	○
FD-51	Multi-step speed 0 given channel	0: FD-00 1: VI 2: CI 3: Keypad potentiometer 4: Reserved 5: PID control 6: Keypad setting frequency (F0-08), can be modified via UP/DN	0	○
FE Group: Torque Control & Optimized Parameters				
FE-00	Speed/torque control mode selection	0: Speed control 1: Torque control	0	◎
FE-01	Torque setting source selection in torque control mode	0: Reserved 1: VI 2: CI 3: Reserved 4: Reserved 5: Communication 6: Min (VI, CI) 7: Max (VI, CI)	0	◎
FE-02	Reserved			
FE-03	Torque setting through keypad in torque control mode	-200.0% ~ 200.0%	150.0%	○
FE-04	0Hz PWM output control mode	0: Invalid 1: Valid	0	○
FE-05	Forward maximum frequency in torque control mode	0.00Hz ~ F0-10 (maximum frequency)	50.00Hz	○
FE-06	Reverse maximum frequency in torque control mode	0.00Hz ~ F0-10 (maximum frequency)	50.00Hz	○

Function code	Name	Detailed instruction	Factory default	Modify
FE-07	ACC time in torque control mode	0.00s ~ 65000s	0.00s	<input type="radio"/>
FE-08	DEC time in torque control mode	0.00s ~ 65000s	0.00s	<input type="radio"/>
FE-09	DPWM switching upper limit frequency	0.00Hz ~ 15.00Hz	12.00Hz	<input type="radio"/>
FE-10	PWM regulation mode	0: Asynchronous mode 1: Synchronous mode	0	<input type="radio"/>
FE-11	Dead zone compensation mode selection	0: no compensation 1: compensation mode 1 2: compensation mode 2	1	<input type="radio"/>
FE-12	Depth of random PWM	0: Random PWM invalid 1~10: depth of random PWM	0	<input type="radio"/>
FE-13	Fast current limitation enable	0: Disable 1: Enable	1	<input type="radio"/>
FE-14	Current detection compensation	0~100	5	<input type="radio"/>
FE-15	SVC optimized mode selection	0: No optimized 1: Optimized mode 1 2: Optimized mode 2	1	<input type="radio"/>
FE-16	Under voltage level setting	60% ~ 140%	80%	<input type="radio"/>

6.2 Monitoring Parameter Table (U0 group)

Function code	Name	Minimum unit
U0-00	Running frequency (Hz)	0.01Hz
U0-01	Setting frequency (Hz)	0.01Hz
U0-02	DC bus voltage (V)	0.1V
U0-03	Output voltage (V)	1V
U0-04	Output current (A)	0.01A
U0-05	Output power (kW)	0.1kW
U0-06	Output torque (%)	0.1%
U0-07	MI input status	1
U0-08	MO output status	1
U0-09	VI voltage (V)	0.01V
U0-10	CI voltage (V)	0.01V
U0-11	Reserved	1°C
U0-12	Count value	1
U0-13	Length value	1
U0-14	Load speed	1
U0-15	PID setting	1
U0-16	PID feedback	1
U0-17	PLC step	1
U0-18	Reserved	
U0-19	Feedback speed (unit 0.1Hz)	0.1Hz
U0-20	Remain running time	0.1Min
U0-21	VI voltage before calibration	0.001V
U0-22	CI voltage before calibration	0.001V
U0-23	Reserved	
U0-24	linear speed	1m/Min
U0-25	Current power-on time	1Min
U0-26	Current running time	0.1Min
U0-27	Reserved	
U0-28	Communication setting value	0.01%
U0-29	Reserved	
U0-30	Main frequency A display	0.01Hz
U0-31	Auxiliary frequency B display	0.01Hz

Chapter 7 Trouble Shooting

7.1 Fault and Trouble Shooting

Solution	<ol style="list-style-type: none"> 1. Inspect whether motor damaged, insulation worn or cable damaged 2. Install a reactor or output filter 3. Check if the air duct is blocked and if the fan is in normal status, and resolve the existing problems 4. Make sure the cables are connected well 5, 6, 7. Ask for technical support
Fault Name	Over current when acceleration
Fault Code	Err02
Reason	<ol style="list-style-type: none"> 1. Short-circuit or ground fault occurred at inverter output side 2. Control mode is vector control but don't perform auto-tuning 3. The acceleration time is too short 4. The manual torque boost or V/f curve is not proper 5. The voltage is too low 6. Start the running motor 7. Load is added suddenly during the acceleration 8. Power selection of inverter is too small
Solution	<ol style="list-style-type: none"> 1. Inspect whether motor damaged, insulation worn or cable damaged 2. Identify the motor parameters 3. Increase the acceleration time 4. Adjust the manual torque boost or V/F curve 5. Make the voltage in the normal range 6. Select speed tracking start or start the motor till it stops 7. Cancel the sudden added load 8. Select bigger power inverter
Fault Name	Over-current when deceleration

Fault Code	Err03
Reason	<ol style="list-style-type: none"> 1. Short-circuit or ground fault occurred at inverter output side 2. Control mode is vector control but don't perform auto-tuning 3. The deceleration time is too short 4. The voltage is too low 5. Load is added suddenly during the deceleration 6. Have not installed braking unit and braking resistor
Solution	<ol style="list-style-type: none"> 1. Inspect whether motor damaged, insulation worn or cable damaged 2. Identify the motor parameters 3. Increase the deceleration time 4. Make the voltage in the normal range 5. Cancel the sudden added load 6. Install braking unit and braking resistor

Fault Name	Over-current when constant speed running
Fault Code	Err04
Reason	<ol style="list-style-type: none"> 1. Short-circuit or ground fault occurred at inverter output 2. Control mode is vector control but don't perform auto-tuning 3. The voltage is too low 4. Load is added suddenly during running 5. Power selection of inverter is too small
Solution	<ol style="list-style-type: none"> 1. Inspect whether motor damaged, insulation worn or cable damaged 2. Identify the motor parameters 3. Make the voltage in the normal range 4. Cancel the sudden added load 5. Select bigger power inverter

Fault Name	Over-voltage when acceleration
Fault Code	Err05
Reason	<ol style="list-style-type: none"> 1. The input voltage is too high 2. There is external force driving the motor to run during acceleration 3. The acceleration time is too short 4. Have not installed braking unit and braking resistor
Solution	<ol style="list-style-type: none"> 1. Make the voltage in the normal range 2. Cancel the external force 3. Increase the acceleration time 4. Install braking unit and braking resistor

Fault Name	Over-voltage when deceleration
Fault Code	Err06
Reason	<ol style="list-style-type: none"> 1. The input voltage is too high 2. There is external force driving the motor to run during deceleration 3. The deceleration time is too short 4. Have not installed braking unit and braking resistor
Solution	<ol style="list-style-type: none"> 1. Make the voltage in the normal range 2. Cancel the external force 3. Increase the deceleration time 4. Install braking unit and braking resistor

Fault Name	Over-voltage when constant speed running
Fault Code	Err07
Reason	<ol style="list-style-type: none"> 1. The input voltage is too high 2. There is external force driving the motor to run during the inverter running
Solution	<ol style="list-style-type: none"> 1. Make the voltage in the normal range 2. Cancel the external force or install braking resistor

Fault Name	Power-supply fault
Fault Code	Err08
Reason	<ol style="list-style-type: none"> 1. The input voltage is out of range
Solution	<ol style="list-style-type: none"> 1. Make the voltage in the normal range

Fault Name	Under-voltage
Fault Code	Err09
Reason	<ol style="list-style-type: none"> 1. Instantaneous power-off 2. The input voltage is out of range 3. DC Bus voltage is abnormal 4. The rectifier bridge and buffer resistor are abnormal 5. The power board is abnormal 6. The control board is abnormal
Solution	<ol style="list-style-type: none"> 1. Fault Reset 2, 3. Make the voltage in the normal range 4, 5, 6. ask for technical support

Fault Name	Inverter over load
Fault Code	Err10
Reason	<ol style="list-style-type: none"> 1. The load is too heavy or motor blockage occurs 2. Power selection of inverter is too small
Solution	<ol style="list-style-type: none"> 1. Reduce the load, check the status of motor & machinery 2. Select bigger power inverter

Fault Name	Motor over load
Fault Code	Err11
Reason	<ol style="list-style-type: none"> 1. FA-00 and PA-01 is set improperly 2. The load is too heavy or motor blockage occurs 3. Power selection of inverter is too small
Solution	<ol style="list-style-type: none"> 1. Set FA-00 and PA-01 properly 2. Reduce the load, check the status of motor & machinery 3. Select bigger power inverter

Fault Name	Reserved
Fault Code	Err12

Fault Name	Output phase failure
Fault Code	Err13
Reason	<ol style="list-style-type: none"> 1. The connection between inverter and motor is abnormal 2. Output voltage unbalance during the motor running 3. The power board is abnormal 4. The IGBT module is abnormal
Solution	<ol style="list-style-type: none"> 1. Inspect whether motor damaged, insulation worn or cable damaged 2. Make sure the motor three phase winding is normal 3, 4. Ask for technical support

Fault Name	IGBT module over-heat
Fault Code	Err14
Reason	<ol style="list-style-type: none"> 1. Ambient temperature is too high 2. Air duct is blocked 3. Cooling fans are broken 4. Thermal resistor(temperature sensor) of the module is broken 5. IGBT module is broken
Solution	<ol style="list-style-type: none"> 1. Reduce the ambient temperature 2. Clear the air duct 3. Replace cooling fans 4, 5. Ask for technical support

Fault Name	External device fault
Fault Code	Err15
Reason	MI terminal receives an external fault signal generated by peripheral device
Solution	Find out the fault source, solve it and reset the inverter

Fault Name	Communication fault
Fault Code	Err16
Reason	<ol style="list-style-type: none"> 1. Master computer works abnormal 2. Communication cable is abnormal 3. FC group parameters are set improperly
Solution	<ol style="list-style-type: none"> 1. Check the connection of master computer 2. Check the communication connection 3. Set FC group parameters properly

Fault Name	DC contactor fault
Fault Code	Err17
Reason	<ol style="list-style-type: none"> 1. Power board or power supply board are abnormal 2. DC contactor is abnormal
Solution	<ol style="list-style-type: none"> 1. Replace power board or power supply board 2. Replace DC contactor

Fault Name	Current detection fault
Fault Code	Err18
Reason	<ol style="list-style-type: none"> 1. Hall sensor is abnormal 2. The power board is abnormal
Solution	<ol style="list-style-type: none"> 1. Check hall sensor and connection 2. Replace the power board

Fault Name	Auto-tuning fault
Fault Code	Err19
Reason	<ol style="list-style-type: none"> 1. Motor parameters are set improperly 2. Parameter identification process is delayed
Solution	<ol style="list-style-type: none"> 1. Set parameters according to the motor nameplate 2. Check the cables connecting inverter with motor

Fault Name	Reserved
Fault Code	Err20

Fault Name	EEPROM read/write fault
Fault Code	Err21
Reason	1. EEPROM chip is broken
Solution	1. Replace the control board

Fault Name	Inverter hardware fault
Fault Code	Err22
Reason	1. Over voltage 2. Over current
Solution	1. Handle as over voltage fault 2. Handle as over current fault

Fault Name	Motor short-circuit to ground
Fault Code	Err23
Reason	1. The motor is short-circuit to ground
Solution	1. Replace cables or motor

Fault Name	Reserved
Fault Code	Err24

Fault Name	Reserved
Fault Code	Err25

Fault Name	Accumulated running time arrival
Fault Code	Err26
Reason	1. The accumulated running time reaches the setting value
Solution	1. Clear the record information via parameter initialization function

Fault Name	Reserved
Fault Code	Err27

Fault Name	Reserved
Fault Code	Err28

Fault Name	Accumulated power-on time arrival
Fault Code	Err29
Reason	1. The accumulated power-on time reaches the setting value
Solution	1. Clear the record information via parameter initialization function

Fault Name	Off-load fault
Fault Code	Err30
Reason	1. The inverter running current is smaller than FA-64
Solution	1. Confirm if the load breaks away and FA-64 & FA-65 are set properly

Fault Name	PID feedback lost when running
Fault Code	Err31
Reason	1. PID feedback is smaller than F9-26
Solution	1. Check PID feedback signal or set F9-26 properly

Fault Name	Current-limiting fault
Fault Code	Err40
Reason	1. Whether the load is heavy or the motor is blocked 2. Power selection of inverter is too small.
Solution	1. Reduce the load and detect the motor & machinery condition 2. Select bigger power inverter

Fault Name	Reserved
Fault Code	Err41, Err42, Err43, Err45, Err51

7.2 Common Faults and Solutions

Fault	Reason	Solution
No display when power-on	1, The input voltage is 0 or too low. 2, The switching power supply on the drive board is broken. 3, Rectifier bridge is broken. 4, Buffer resistors are broken. 5, The control board or keypad is broken. 6, Cables are loose connection	1, Check the input power-supply. 2, Check the DC bus voltage 3, Reconnect the cables 4, Ask for technical support
Display HC when power-on	1, Loose connection of the control board and power board. 2, Control board is broken. 3, Motor or motor cables short-circuited with ground. 4, Hall sensor is broken. 5, Input voltage is too low	1, Check the mentioned reasons one by one. 2, Ask for technical support
Display HC when starting the inverter, and inverter stops immediately	1, Fans are broken or air duct is blocked. 2, The control cables are short-circuited.	1, Measure the insulation of control cables with magneto-ohmmeter. 2, Ask for technical support
Err23 is displayed when power-on	1, The motor or the output line is short-circuited to the ground. 2, The inverter is damaged.	1, Measure the insulation of the motor and output line with magneto-ohmmeter. 2, Ask for technical support
Err14 happens frequently	1, Carrier frequency setting is too high. 2, Fans are broken or air duct is blocked. 3, The inverter inside components are broken (such as thermocouple).	1, Reduce the carrier frequency (F0-15). 2, Replace fans, clear the air duct. 3, Ask for technical support

Motor does not run after starting the inverter	<ol style="list-style-type: none"> 1, Motor and motor cables are abnormal. 2, The inverter parameters are set improperly (motor parameters). 3, The connection of the cables of the driver board and control board are not good. 4, The driver board is broken 	<ol style="list-style-type: none"> 1, Make sure the connection of the inverter and motor is very well. 2, Replace the motor or clear the mechanical failure. 3, Check & reset the motor parameters. 4, Ask for technical support.
Digital input (MIX) terminal is invalid	<ol style="list-style-type: none"> 1, The parameter is set improperly. 2, The external signal is wrong. 3, The jumper between OP and 24V is loose. 4, The control board is broken. 	<ol style="list-style-type: none"> 1, Check & reset F5 group parameters. 2, Reconnect the external signal cable. 3, Reconnect the jumper between OP and 24V. 4, Ask for technical support.
Over voltage and over current fault happens frequently	<ol style="list-style-type: none"> 1, Motor parameters are set improperly. 2, The ACC/DEC time is improper. 3, The load has big fluctuation. 	<ol style="list-style-type: none"> 1, Reset motor parameters or perform auto tuning. 2, Set proper ACC/DEC time. 3, check the load condition.
Err17 is displayed when power-on or running	The DC contactor is not closed	<ol style="list-style-type: none"> 1, Check whether the contactor cables are loose.. 2, Check whether the contactor is broken. 3, Check whether the 24V power supply of contactor is abnormal.
Power on display 8.8.8.8.8	<ol style="list-style-type: none"> 1, The control board is broken. 2, Loose connection of control board and power board. 	<ol style="list-style-type: none"> 1, Replace the control board. 2, Reconnect the cable between control board and power board

Chapter 8 EMC (Electromagnetic Compatibility)

8.1 Definition

Electromagnetic compatibility is the ability of the electric equipment to work in the electromagnetic interference environment and implement its function stably without interferences in the electromagnetic environment.

8.2 EMC Standard Description

In accordance with the requirements of the national standard GB/T12668.3, the inverter needs to comply with electromagnetic interference and anti-electromagnetic interference requirements.

Products apply the latest international standard—IEC/EN61800-3: 2004 (Adjustable speed electrical power drive systems part 3: EMC requirements and specific test methods), which is equivalent to the national standard GB/T12668.3.

IEC/EN61800-3 assesses the inverter in terms of electromagnetic interference and anti-electronic interference. Electromagnetic interference mainly tests the radiation interference, conduction interference and harmonics interference on the inverter (required for the inverter for civil use). Anti-electromagnetic interference mainly tests the conduction interference rejection, radiation interference rejection, surge interference rejection, fast and mutable pulse group interference rejection, ESD interference rejection and power low frequency end interference rejection (specific test items including: 1. Interference rejection tests of input voltage sag, interrupt and change; 2. Phase conversion interference rejection test; 3. Harmonic input interference rejection test; 4. Input frequency change test; 5. Input voltage unbalance test; 6. input voltage fluctuation test).

The tests should be conducted strictly in accordance with the above requirements of IEC/ EN61800-3, and the products of our company are installed and used according to Section 7.3 and have good electromagnetic compatibility in general industry environment.

8.3 EMC Guide

8.3.1 Harmonic effect

Higher harmonics of power supply may damage the inverter. Thus, at some places where mains quality is rather poor, it is recommended to install AC input reactor.

8.3.2 Electromagnetic interference and installation precautions

There are two kinds of electromagnetic interferences, one is interference of electromagnetic noise in the surrounding environment on the inverter, and the other is interference of inverter on the surrounding equipment.

Installation precautions:

- 1) The earth wires of the Inverter and other electric products should be well grounded;
- 2) The power input and output power cables of the inverter and weak current signal cables (e.g. control line) should not be arranged in parallel and vertical arrangement is preferable.
- 3) It is recommended that the output power cables of the inverter employ shield cables or steel pipe shielded cables and that the shielding layer be earthed reliably. The lead cables of the equipment suffering interferences are recommended to employ twisted-pair shielded control cables, and the shielding layer should be earthed reliably.
- 4) When the length of motor cable is longer than 100 meters, it needs to install output filter or reactor.

8.3.3 Handling method for the interferences of the surrounding equipment on the inverter

The electromagnetic interference on the inverter is generated because plenty of relays, contactors and electromagnetic brakes are installed near the inverter. When the inverter has error action due to the interferences, the following measures can be taken:

- 1) Install surge suppressor on the devices generating interference;
- 2) Install filter at the input end of the inverter. Refer to Section 7.3.6 for the specific operations;
- 3) The lead cables of the control signal cable of the inverter and the detection line employ shielded cable and the shielding layer should be earthed reliably.

8.3.4 Handling method for the interferences of inverter on the surrounding equipment

These interferences include two types: one is radiation interference of the inverter, and the other is conduction interference of the inverter. These two types of interferences cause the surrounding electric equipment to suffer electromagnetic or electrostatic induction. The surrounding equipment hereby produces error action. For different interferences, it can be handled by referring to the following methods:

- 1) For the measuring meters, receivers and sensors, their signals are generally weak. If they are placed nearby the inverter or together with the inverter in the same control cabinet, they are easy to suffer interference and thus generate error actions. It is recommended to handle with the following methods: Put in places far away from the interference source; do not arrange the signal cables with the power cables in parallel and never bind them together; both the signal cables and power cables employ shielded cables and are well earthed; install ferrite magnetic ring (with suppressing frequency of 30 to 1,000MHz) at the output side of the inverter and wind it 2 to 3 cycles; install EMC output filter in more severe conditions.
- 2) When the equipment suffering interferences and the inverter use the same power supply, it may cause conduction interference. If the above methods cannot remove the interference, it should install EMC filter between the inverter and the power supply (refer to Section 8.3.6 for the prototyping operation); the

surrounding equipment is separately earthed, which can avoid the interference caused by the leakage current of the inverter's earth wire when common earth mode is adopted.

- 3) The surrounding equipment is separately earthed, which can avoid the interference caused by the leakage current of the inverter's earth wire when common earth mode is adopted.

8.3.5 Leakage current and handling

There are two forms of leakage current when using the inverter. One is leakage current to the earth, and the other is leakage current between the cables.

- 1) Factors influencing the leakage current to the earth and the solutions:

There are distributed capacitance between the lead cables and the earth. The larger the distributed capacitance is, the larger the leakage current will be. The distributed capacitance can be reduced by

effectively reducing the distance between the inverter and the motor. The higher the carrier frequency is, the larger the leakage current will be. The leakage current can be reduced by reducing the carrier frequency. However, reducing the carrier frequency may result in addition of motor noise. Note that additional installation of reactor is also an effective method to remove the leakage current.

The leakage current may increase following the addition of circuit current. Therefore, when the motor power is high, the corresponding leakage current will be high too.

- 2) Factors of producing leakage current between the cables and solutions:

There is distributed capacitance between the output cables of the inverter. If the current passing the lines has higher harmonic, it may cause resonance and thus result in leakage current. If thermal relay is used, it may generate error action.

The solution is to reduce the carrier frequency or install output reactor. It is recommended that thermal relay not be installed before the motor when using the inverter, and that electronic over current protection function of the inverter be used instead.

8.3.6 Precautions for Installing EMC input filter at the input end of power supply

- 1) When using the inverter, please follow its rated values strictly. Since the filter belongs to Classification I electric appliances, the metal enclosure of the filter should be large and the metal ground of the installing cabinet should be well earthed and have good conduction continuity. Otherwise there may be danger of electric shock and the EMC effect may be greatly affected.
- 2) Through the EMC test, it is found that the filter ground must be connected with the PE end of the inverter at the same public earth. Otherwise the EMC effect may be greatly affected.
- 3) The filter should be installed at a place close to the input end of the power supply as much as possible.

Chapter 9 MODBUS Communication Protocol

KD100 & KD200 series inverter provides RS485 communication interface, and adopts MODBUS communication protocol. User can realize centralized monitoring through PC/PLC, host computer, and also can set inverter's operating commands, modify or read function parameters, read operating status and fault information, etc.

9.1 About Protocol

This serial communication protocol defines the transmission information and use format in the series communication. It includes the formats of master-polling, broadcast and slave response frame, and master coding method with the content including slave address (or broadcast address), command, transmitting data and error checking. The response of slave adopts the same structure, including action confirmation, returning the data and error checking etc. If slave takes place the error while it is receiving the information or cannot finish the action demanded by master, it will send one fault signal to master as a response.

9.2 Application Method

The inverter could be connected into a "Single-master & Multi-slaves" PC/PLC control network with RS485 bus.

9.3 Bus Structure

(1) Interface mode

RS485

(2) Transmission mode

There provide asynchronous series and half-duplex transmission mode. At the same time, just one can send the data and the other only receives the data between master and slave. In the series asynchronous communication, the data is sent out frame by frame in the form of message.

(3) Topological structure

In Single-master Multi-slave system, the setup range of slave address is 0 to 247. 0 refers to broadcast communication address. The address of slave must be exclusive in the network. That is basic condition of MODBUS communication.

a. Connect with PC

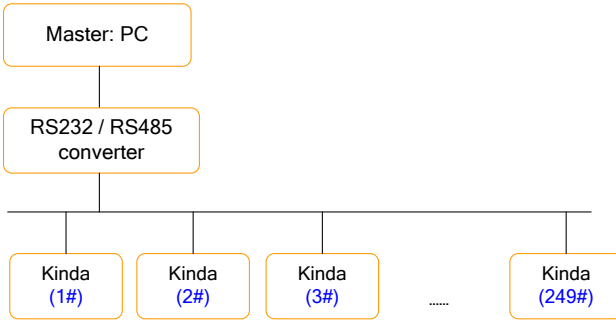

b. Connect with PLC

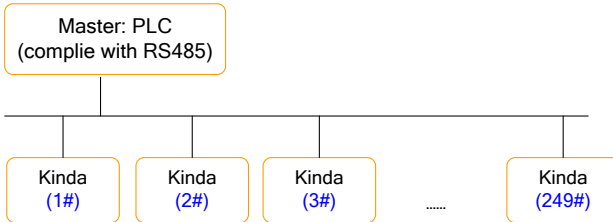

9.4 Interfaces and wiring connection

KD100 & KD200 series inverter provides S+ and S- interfaces for Modbus communication.

There are two kinds of communication type suitable for Modbus connection;

(1) Daisy chain connection

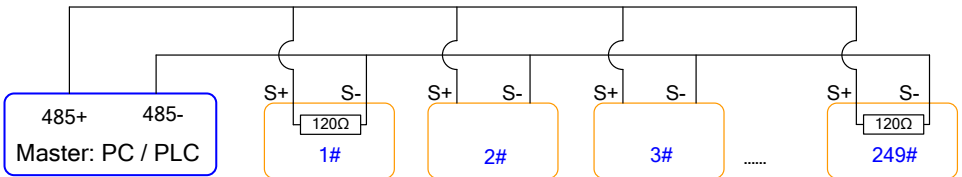

Notice: the **first one** and **last one** inverters should connect the terminal resistor.

(2) star connection

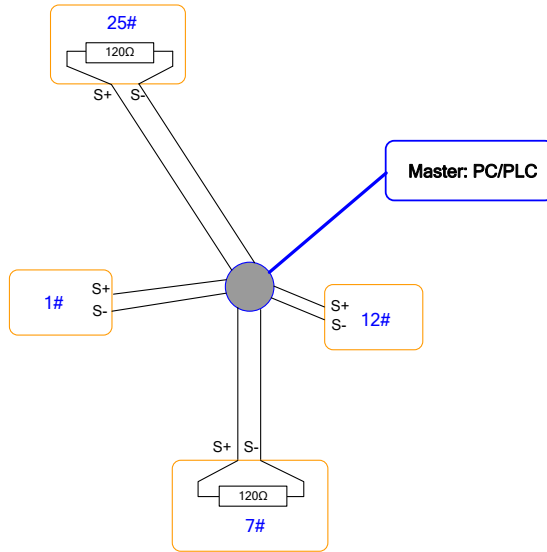

Notice: the furthest one (25#) and second furthest one (7#) inverters should connect the terminal resistor.

9.5 Protocol Description

KD100 & KD200 series inverter communication protocol is a kind of asynchronous serial master-slave communication protocol. In the network, only one equipment (master) can build a protocol (Named as “Inquiry/Command”). Other equipment (slave) response “Inquiry/Command” of master only by providing the data, or doing the action according to the master’s “Inquiry/Command”. Here, master is Personnel Computer, Industrial control equipment or Programmable logical controller, and the slave is inverter or other communication equipment with the same communication protocol. Master not only can visit some slave separately for communication, but also sends the broadcast information to all the slaves. For the single “Inquiry/Command” of master, all of slaves will return a signal that is a response; for the broadcast information provided by master, slave needs not feedback a response to master.

9.6 Communication Data Structure

MODBUS protocol communication data format of KD100 & KD200 series inverters are shown as below:

In RTU mode, the Modbus minimum idle time between frames should be no less than 3.5 bytes. The checksum adopts CRC-16 method. All data except checksum itself sent will be counted into the calculation. Please refer to section: CRC Check for more information. Note that at least 3.5 bytes of Modbus idle time should be kept and the start and end idle time need not be summed up to it.

The entire message frame must be transmitted as a continuous data stream. If a idle time is more than 1.5

bytes before completion of the frame, the receiving device flushes the incomplete message and assumes that the next byte will be the address field of a new message. Similarly, if a new message begins earlier than 3.5 bytes interval following a previous message, the receiving device will consider it as a continuation of the previous message. Because of the frame's confusion, at last the CRC value is incorrect and communication fault will occur.

RTU frame format:

START	Transmission time of 3.5 bytes
Slave Address	Communication address : 0 to 249
Command Code	03H: Read slave parameters 06H: Write slave parameters
DATA (N-1)	Data: Function code parameter address, the number of function code parameter, Function code parameter, etc.
DATA (N-2)	
.....	
DATA 0	
CRC Low byte	Detection Value: CRC value
CRC High byte	
END	Transmission time of 3.5 bytes

9.7 Command Code and Communication Data Description

9.7.1 Command code: 03H, reads N words. (There are 12 characters can be read at the most.)

For example: The inverter start address F002 of the slave 01 continuously reads two consecutive values.

Master command information

Address	01H
Command Code	03H
Start Address High byte	F0H
Start Address Low byte	02H
Register Number High byte	00H
Register Number Low byte	02H
CRC Low byte	56H
CRC High byte	CBH

Slave responding information

Address	01H
Command Code	03H
Byte Number	04H
Data F002H High byte	00H
Data F002H Low byte	00H
Data F003H High byte	00H
Data F003H Low byte	01H
CRC Low byte	3BH
CRC High byte	F3H

9.7.2 Command code: 06H, write a word

For example: Write 5000(1388H) into address F00AH, slave address 02H.

Master command information

Address	02H
Command Code	06H
Data Address High byte	F0H
Data Address Low byte	0AH
Data Content High byte	13H
Data Content Low byte	88H
CRC Low byte	97H
CRC High byte	ADH

Slave responding information

Address	02H
Command Code	06H
Data Address High byte	F0H
Data Address Low byte	0AH
Data Content High byte	13H

Data Content Low byte	88H
CRC Low byte	97H
CRC High byte	ADH

9.7.3 CRC checking

In RTU mode, messages include an error-checking field that is based on a CRC method. The CRC field checks the contents of the entire message. The CRC field is two bytes, containing a 16-bit binary value. The CRC value is calculated by the transmitting device, which appends the CRC to the message. The receiving device recalculates a CRC during receipt of the message, and compares the calculated value to the actual value received in the CRC field. If the two values are not equal, an error results.

The CRC is started by 0xFFFF. Then a process begins of applying successive eight-bit bytes of the message to the current contents of the register. Only the eight bits of data in each character are used for generating the CRC. Start and stop bits, and the parity bit, do not apply to the CRC.

During generation of the CRC, each eight-bit character is exclusive ORed with the register contents. Then the result is shifted in the direction of the least significant bit (LSB), with a zero filled into the most significant bit (MSB) position. The LSB is extracted and examined. If the LSB was a 1, the register is then exclusive ORed with a preset, fixed value. If the LSB was a 0, no exclusive OR takes place. This process is repeated until eight shifts have been performed. After the last (eighth) shift, the next eight-bit byte is exclusive ORed with the register's current value, and the process repeats for eight more shifts as described above. The final contents of the register, after all the bytes of the message have been applied, is the CRC value.

When the CRC is appended to the message, the low byte is appended first, followed by the high byte. The following are C language source code for CRC-16.

```

unsigned int crc_cal_value(unsigned char *data_value, unsigned char data_length)
{
    int i;
    unsigned int crc_value = 0xffff;
    while(data_length--)
    {
        crc_value ^= *data_value++;
        for(i=0;i<8;i++)
        {
            if(crc_value&0x0001)
                crc_value = (crc_value>>1)^0xa001;
            else

```

```

        crc_value = crc_value>>1;
    }
}
return(crc_value);
}

```

9.7.4 Address definition of communication parameter

Here is about address definition of communication parameter. It's used to control the inverter operation, status and related parameter setting.

The mark rules of function code parameters address:

The group number and mark of function code is the parameter address for indicating the rules.

(1) F0~FF group parameter address:

High byte: F0 ~ FF(F group),

Low byte: 00 to FF

(2) U0 group parameter address:

High byte: 70H,

Low byte: 00 to FF

For example:

F3-12, address indicates to 0xF30C

FC-05, address indicates to 0xFC05

U0-03, address indicates to 0x7003

Note:

1. Group FF: Either the parameter cannot be read, nor be changed.
2. Group U0: Only for reading parameter, cannot be changed parameters.
3. Some parameters cannot be changed during operation; some parameters regardless of what kind of status the inverter in, the parameters cannot be changed. Change the function code parameters, pay attention to the scope of the parameters, units, and relative instructions.

Besides, due to EEPROM be frequently stored, it will reduce the lifetime of EEPROM. So in the communication mode, some function codes needn't be stored, only change the RAM value.

For F group parameters, to achieve this function, just change high bit F of the function code into 0..

Corresponding function code addresses are indicated below:

(1) F0~FF group parameter address:

High byte: 00 to FF,

Low byte: 00 to FF

(2) U0 group parameter address:

High byte: 70H,

Low byte: 00 to FF

For example:

F3-12, address indicates to 030C

FC-05, address indicates to 0C05

These addresses can only act writing RAM, it cannot act reading. When act reading, it is an invalid address.

(2) Stop/start parameter address

Parameter Address	Parameter Description
1000H	* Communication setting value (-10000 to 10000) (Decimal)
1001H	Running frequency
1002H	Bus voltage
1003H	Output voltage
1004H	Output current
1005H	Output power
1006H	Output torque
1007H	Running speed
1008H	MI input status
1009H	FM, AM output status
100AH	VI voltage
100BH	CI voltage
100CH	Reserved
100DH	Counting value input
100EH	Length value input
100FH	Load speed
1010H	PID setting
1011H	PID feedback

Parameter Address	Parameter Description
1012H	Simple PLC running step
1013H	Reserved
1014H	Feedback speed, unit is 0.1Hz
1015H	Remain running time
1016H	VI voltage before calibration
1017H	ci voltage before calibration
1018H	Reserved
1019H	Linear speed
101AH	Current power on time
101BH	Current running time
101CH	Reserved
101DH	Communication setting value
101EH	Actual feedback speed
101FH	Main frequency A display
1020H	Auxiliary frequency B display

Note:

Communication setting value is the percentage of relative value, and 10,000 corresponds to 100.00%, -10000 corresponds to -100.00%.

To the data of frequency, the percentage is the percentage of relative maximum frequency (F0-10).

To the data of torque, the percentage is F2-10 (torque upper limit).

(3) Control command input to inverter (write only)

Command Word Address	Command Function
2000H	0001: Forward running
	0002: Reverse running
	0003: Forward jog
	0004: Reverse jog
	0005: Coast to stop
	0006: Deceleration to stop
	0007: Fault reset

(4) Read inverter status: (read only)

Status Word Address	Status Word Function
3000H	0001: Forward running
	0002: Reverse running
	0003: Stop

(5) Parameters locking password check: (If the return is 8888H, it means the password check passes.)

Password Address	Content of Input password
1F00H	*****

(6) Digital output terminal control: (write only)

Command Address	Command Content
2001H	BIT0: MO1 output control
	BIT1: MO2 output control
	BIT2: RELAY1 output control
	BIT3: RELAY2 output control
	BIT4 ~ BIT9: Reserved

(7) Analog output AM control: (write only)

Command Address	Command Content
2002H	0~7FFF refers to 0%~100%

(8) Analog output FM control: (write only)

Command Address	Command Content
2003H	0~7FFF refers to 0%~100%

(9) Pulse output control: (write only)

Command Address	Command Content
2004H	0~7FFF refers to 0% ~100%

(10) Inverter fault code description:

Inverter Fault Address	Inverter Fault Information
8000H	0000: No fault
	0001: Reserved
	0002: Over current when acceleration
	0003: Over current when deceleration
	0004: Over current when constant speed running
	0005: Over voltage when acceleration
	0006: Over voltage when deceleration
	0007: Over voltage when constant speed running
	0008: Buffer resistor overload
	0009: Under voltage fault
	000A: Inverter overload
	000B: Motor overload
	000C: Reserved
	000D: Output phase failure
	000E: Module overheat
	000F: External fault

0010: Communication fault
0011: Contactor fault
0012: Current detection fault
0013: Motor auto-tuning fault
0014: Reserved
0015: Parameter R/W fault
0016: Inverter hardware fault
0017: Motor short circuit to ground
0018: Reserved
0019: Reserved
001A: Running time arrival
001B: Customized fault 1
001C: Customized fault 2
001D: Power on time arrival
001E: Off load
001F: PID feedback lost when running
0028: Fast current limiting over time fault
0029: Reserved
002A: Speed deviation oversize
002B: Motor over speed

9.8 FC Group Communication Parameter Description

FC-00	Baud Rate	Factory Setting	6005
	Setting range	Unit place: Modbus 0: 300BPS 1: 600BPS 2: 1200BPS 3: 2400BPS 4: 4800BPS 5: 9600BPS 6: 19200BPS 7: 38400BPS 8: 57600BPS 9: 115200BPS Tens place: Reserved Hundred place: Reserved Thousand place: Reserved	

This parameter is used to set the data transmission rate between host computer and the inverter. Please note that baud rate of the host computer and inverter must be the same. Otherwise, the communication is impossible. The bigger baud rate is, the faster communication is.

FC-01	Data Format	Factory Setting	0
	Setting range	0: No check: Data format <8-N-2> 1: Even parity Check :data format <8-E-1> 2: Odd Parity Check : data format <8-O-1> 3: No check: Data format <8-N-1>	

The setting data format of host computer and inverter must be the same; otherwise, the communication is impossible.

FC-02	Local Address	Factory Setting	1
	Setting range	1~249, 0 is broadcast address	

When the local address is set to be 0, that is broadcast address, it can realize the broadcast function of host computer.

Local address must be unique (except broadcast address). This is the base of point-to-point communication between host computer and inverter.

FC-03	Response Delay	Factory Setting	2ms
	Setting range	0~20ms	

Response delay: It refers to the interval time from the inverter finishes receiving data to sending data to the host computer. If the response delay is less than system processing time, then the response delay is based on the system processing time. If the response delay is more than system processing time, after the system processing the data, it should be delayed to wait until the response delay time arrives, then sending data to host computer.

FC-04	Communication Timeout	Factory Setting	0.0s
	Setting range	0.0s (invalid) 0.1~60.0s	

When the function code set to be 0.0 s, the communication timeout parameter is invalid.

When the function code set to be valid value, if the interval time between the communication and the next communication is beyond the communication timeout, the system will report communication failure error (Err16). At normal circumstances, it is set to be invalid. If in the continuous communication system, set the parameter, you can monitor the communication status.

FC-05	Communication Protocol selection	Factory Setting	31
	Setting range	Unit place: Modbus 0: Nonstandard Modbus protocol 1: Standard Modbus protocol Tens place: Reserved	

FC-05=01: Select standard MODBUS protocol

FC-05=00: When reading the command, the slave return is one byte than the standard MODBUS protocol's, for details refer to communications Data Structure of this protocol.

FC-06	Communication Read Current Resolution	Factory Setting	0
	Setting range	0: 0.01A 1: 0.1A	

It is used to confirm the output current unit when communication reads output current.