

# SuperBus<sup>®</sup> 2000 RS-232 Automation Module

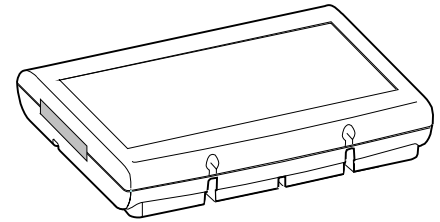

8845G02A.DSF

Document Number: 466-1876 Rev. A  
February 2001

## Installation Instructions

### Product Summary

The ITI SuperBus 2000 RS-232 Automation Module allows you to connect a compatible third-party automation device to any compatible system panel.

For additional security, a magnetic switch can be added and connected to the built-in input zone to provide module tamper protection.

Power for the module is provide by the system panel.

### Features

- RS-232 automation port.
- Supervised, fire-rated zone input.
- On-board status indication.
- SuperBus 2000 automatic addressing data bus.

Figure 1 shows the main module components and Table 1 describes them

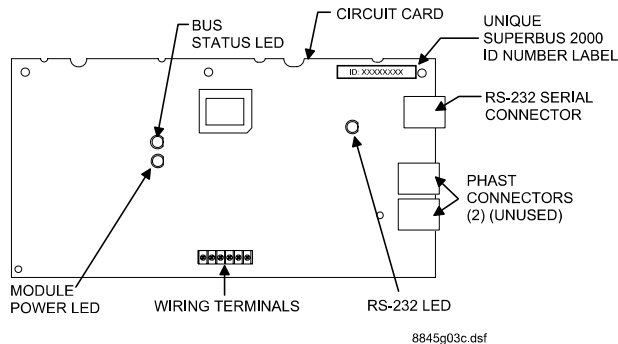

Figure 1. Module Circuit Board Components

Table 1. Module Component Descriptions

Component	Function
Power LED	Indicates module power status.
Bus Status LED	Flashes to indicate normal communication to the panel bus.
RS-232 Status LED	Indicates RS-232 transmission or reception.
Unique ID number Label	Indicates module unique identification number.

Table 1. Module Component Descriptions

Component	Function
RS-232 Connector	Provides connection to automation device.
PHAST Connectors	Not used.
Wiring Terminals	Used for panel SuperBus and module zone input connections.

### Installation Guidelines

- Do not exceed the panel total auxiliary output power when using panel power for bus devices and hardwired sensors that require panel power (see the specific panel *Installation Instructions*).
- Maximum current draw of the module (from the panel) is 35mA.
- Use 4-conductor, 22-gauge or larger wire from the module to the panel.

### Tools and Supplies Needed

- Small blade and Phillips screwdrivers
- Drill and bits for screws and/or anchors
- Case tamper switch and magnet (optional)
- 9 pin RS-232 serial cable

#### Accessory kit includes:

- 3/8-inch self-tapping screws
- #6 panhead screws
- 2K Ohm EOL resistor (49-467)
- Wall anchors

### Installation

The module can be mounted on any interior wall (protected from the elements).

### Installing the Module

The module should be mounted no more than 25 feet from the automation device in the same room.



#### CAUTION

You must be free of static electricity before handling circuit boards. Wear a grounding strap or touch a bare metal surface to discharge static electricity.

**To mount the module on a wall:**

1. Turn off panel power and disconnect backup battery(s).
2. Remove the module cover and circuit card and set them aside (Figure 2).

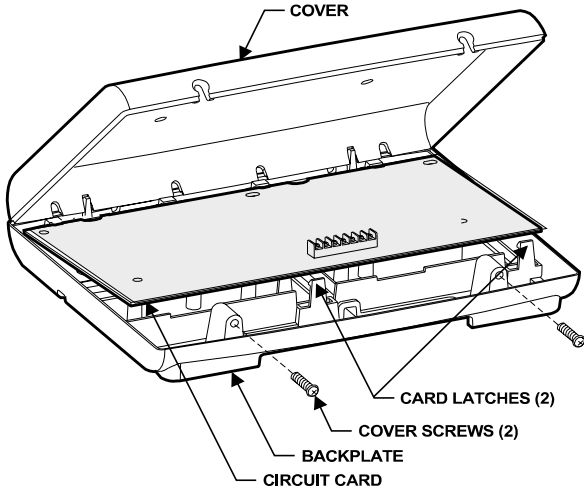

8845G1A.DSF

**Figure 2. Removing Plastic Case Cover and Circuit Card**

3. Place the module backplate on the wall and mark the mounting holes locations (Figure 3).

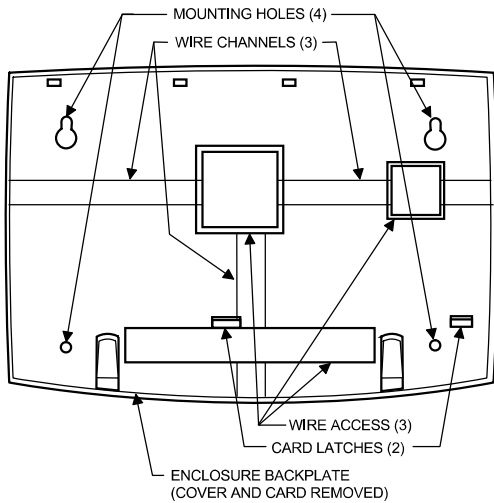

8845G08A.DSF

**Figure 3. Plastic Case Mounting Holes**

4. Drill the holes and insert the appropriate anchors.
5. Secure the back plate to the wall with panhead screws.
6. Snap the circuit card back into the back plate.

**Panel Wiring**

This section describes how to wire the module to the panel and how to connect hardwire sensors to the module. Refer

to Figure 5 and Table 2 for wiring examples and connection descriptions.

**To wire the module to the panel:**

1. Make sure power is turned off to the panel.
2. Make sure the power transformer and backup battery(s) are disconnected from the panel.

**To wire the module to the Advent panel:**

1. Wire the module to the panel SuperBus Wiring harness as shown in Figure 4. (Refer to panel *Installation Instructions* for cable types and maximum cable lengths.)
2. Plug the wiring harness into one of the panel SuperBus Connectors.

**Note**

The RS-232 Automation Module is compatible with Advent panels using software version 1.6 or later.

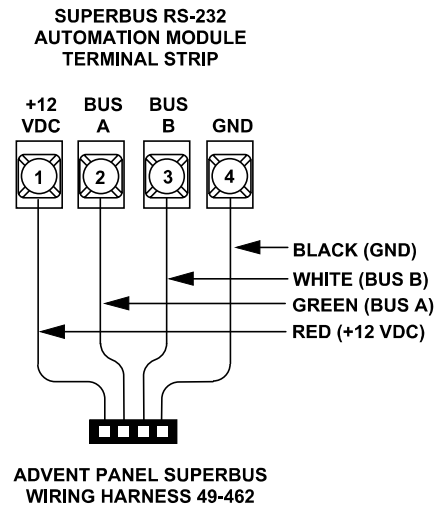

8543110B.DSF

**Figure 4. Advent Panel SuperBus Wiring**

**To connect a device to the module:**

1. Attach the appropriate DB-9 serial cable to the connector on the module (Figure 5). This cable must be less than 25 feet in length.

**Note**

The RS-232 Automation Module's RS-232 port is configured as a DCE device. Therefore it transmits data on pin 2, receives data on pin 3. Pin 5 is the signal ground. All other pins are not used.

If the automation device's RS-232 port is configured as a DTE port, then a "straight through" DB-9 cable must be used. Otherwise a "null modem" cable must be used.

Refer to the automation device instructions for information about its RS-232 port.

2. If necessary set the communication parameters on the automation device's RS-232 port as follows: 8 data bits, 9600 bps, odd parity, 1 stop bit.
3. Connect an input device (if used) to the module zone input terminals (Figure 5)

## Installing a Case Tamper Switch

If the module is visible, you may want to add case tamper detection. Then, if someone opens the cover, the switch opens and causes an alarm. To add module case tampering, install a magnet in the cover and a reed switch into the back plate or case. Wire the switch to the module or one of the panel zone inputs. (See Figure 5 or panel *Installation Instructions*).

## Power Up and Bus Communication

This section describes how to power up the panel and the module and get them communicating with each other.

### To power up the panel and the module:

1. Verify that all wiring at the panel and the module are correct.

2. Reconnect the panel batteries and plug in the power transformer. The module power LED should be on.
3. On initial power up, the panel automatically adds (learns) the module into panel memory. After a few seconds, the module bus status LED should flash at a rapid and random rate to indicate it is learned into the panel.

If the module bus status LED flashes at a steady rate, the module must be manually added (learned) into panel memory. (Refer to the panel *Installation Instructions* for adding SuperBus modules.)

## Programming/Operating the Module

Refer to the panel *Installation Instructions for module* input/output programming and operation.

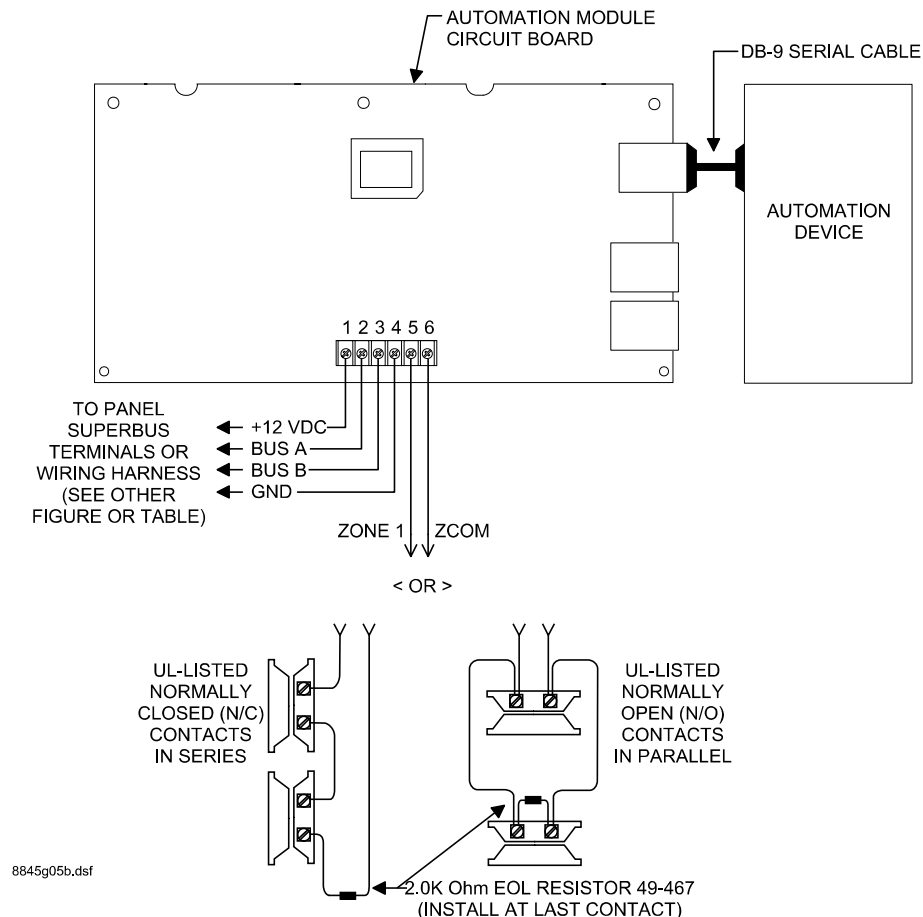

Figure 5. Panel/Module Wiring

## Module Wiring Terminal Connections

**Table 2. SuperBus 2000 Automation Module Terminal Connections**

Terminal	Name	Used For
1	+12V DC	SuperBus DC power supply input. 12 VDC @35 mA maximum draw from panel.
3	BUS A	SuperBus communication connection.
4	BUS B	SuperBus communication connection.
5	GND	SuperBus common ground connection.
6	ZONE 1	Zone 1 input connection.
7	ZCOM	Zone input common connection.

### Testing

Verify proper operation of the automation device. Refer to the automation device instructions for an explanation of proper operation.

### Troubleshooting

#### Module POWER LED stays off.

1. Check module and panel power.
2. Check SuperBus wiring and connections

#### Module BUS STATUS LED stays off.

1. Check SuperBus wiring and connections
2. Check for proper panel/SuperBus module programming and initialization.

#### Module BUS STATUS LED stays on.

1. Re initialize panel and module by turning panel power off and on.
2. Module circuit failure. Replace the module.

#### Module BUS STATUS LED blinks, but no automation device operation.

1. Check that the automation device power is on.
2. If the LED is not blinking at a rapid, random rate, the module is not learned into the panel.
3. Check module and device cables and connections.
4. Check panel/module programming.

5. Check the RS-232 LED. It should blink at least once every 4 seconds.

### Specifications

Compatibility:	Advent (and Custom Versions) security panels. (Software version 1.6 or later)
Power Requirements:	12 VDC nominal, 35 mA maximum draw from panel.
Panel Data Bus:	ITI SuperBus auto addressing digital data bus.
Automation Port:	RS-232, DCE
Zone Input:	One supervised, fire-rated zone.
Storage Temperature:	-30° to 140° F (-34° to 60° C)
Operating Temperature:	32° to 140° F (0° to 60° C)
Maximum Humidity:	95% relative humidity, noncondensing.
Approvals/Listings:	FCC Part 15
Dimensions:	6.0" x 8.5" x 1.5" (L x W x D).
Case Material:	High-Impact, ABS plastic.
Case Color:	Belgian gray.
Installation:	Wall Mount

## Notices

### FCC Part 15 Information to the User

Changes or modifications not expressly approved by Interlogix, Inc. can void the user's authority to operate the equipment.

### FCC Part 15 Class A

This equipment has been tested and found to comply with the limits for a class A digital device, pursuant to part 15 of the FCC rules. These limits are designed to provide reasonable protection against harmful interference when the equipment is operated in a commercial environment.

This equipment generates, uses, and can radiate radio frequency energy and, if not installed and used in accordance with the instruction manual, may cause harmful interference to radio communications. Operation of this equipment in a residential area is likely to cause harmful interference in which case users will be required to correct the interference at their own expense.

### FCC Part 15 Class B

This equipment has been tested and found to comply with the limits for a Class B digital device, pursuant to part 15 of the FCC Rules. These limits are designed to provide reasonable protection against interference in a residential installation.

This equipment generates, uses, and can radiate radio frequency energy and, if not installed and used in accordance with the instructions, may cause harmful interference to radio communications. However, there is no guarantee that interference will not occur in a particular installation.

If this equipment does cause harmful interference to radio or television reception, which can be determined by turning the equipment off and on, the user is encouraged to try to correct the interference by one or more of the following measures:

- Reorient or relocate the receiving antenna.
- Increase the separation between the equipment and receiver.
- Connect the affected equipment and the panel receiver to separate outlets, on different branch circuits.
- Consult the dealer or an experienced radio/TV technician for help.



SECURITY & LIFE SAFETY GROUP

CADDX | ESL | GBC | ITI | SENTROL

ITI | 2266 SECOND STREET NORTH | NORTH SAINT PAUL MN | 800-777-2624 | [www.interlogixinc.com](http://www.interlogixinc.com)

©2001 Interlogix,™ Inc. Interlogix and Concord are trademarks of Interlogix, Inc. ITI, Advent, and SuperBus are registered trademarks of Interlogix, Inc.