



# Jetson Orin Nano Developer Kit Carrier Board

Specification

# Document History

SP-11324-001\_v1.2

Version	Date	Description of Change
1.0	March 20, 2023	Initial release
1.1	May 17, 2023	<ul style="list-style-type: none"><li>&gt; Updated Note in Chapter 1: Introduction with VDD_IN related information.</li><li>&gt; Updated Pin #13 in Table 2-5: DisplayPort Connector Pin Description – J8.</li><li>&gt; Updated Pin #55 and Pin #57 in Table 2-6: M.2 Key E Expansion Slot Pin Description – J10.</li><li>&gt; Added developer kit weight.</li><li>&gt; Updated Figure 5-1: Power Diagram.</li><li>&gt; Updated VDD_5V_SYS in Table 5-2: Interface Supply Current Capabilities.</li><li>&gt; Updated Table 5-3: Supply Current Capabilities per Connector per Supply; replaced VDD_IN with VDD_5V_SYS.</li></ul>
1.2	April 12, 2024	<ul style="list-style-type: none"><li>&gt; Updated Figure 1-4. Jetson Orin Nano Carrier Board Placement – Top View: corrected Pin 1 location on J20 and J21 camera connectors</li></ul>

# Table of Contents

Chapter 1.	Introduction.....	1
1.1	Jetson Orin Nano Module Feature List.....	2
1.2	Carrier Board Feature List .....	2
1.3	Jetson Orin Nano Carrier Board Block Diagram .....	3
Chapter 2.	Jetson Nano Carrier Board Standard Connectors.....	7
2.1	USB Ports .....	7
2.2	Gigabit Ethernet .....	10
2.3	DisplayPort.....	11
2.4	M.2 Key E Expansion Slot .....	12
2.5	M.2 Key M Expansion Slot.....	14
Chapter 3.	Carrier Board Custom Expansion IF Connections.....	18
3.1	Jetson Orin Nano Module Connector.....	18
3.2	Camera Connector.....	18
3.3	40-Pin Expansion Header .....	21
3.4	Button Header .....	24
3.5	Optional CAN Bus Header .....	25
3.6	Fan Connector .....	25
3.7	Optional Battery Back-up Coin Cell Holder .....	26
3.8	DC Power Jack .....	26
3.9	Optional Power-Over Ethernet and Backpower Headers.....	27
Chapter 4.	Mechanical Specification .....	29
Chapter 5.	Interface Power .....	31

# List of Figures

Figure 1-1.	Jetson Orin Nano Block Diagram.....	4
Figure 1-2.	Jetson Orin Nano – Top View (Envelope).....	4
Figure 1-3.	Jetson Orin Nano – Bottom View (Envelope).....	5
Figure 1-4.	Jetson Orin Nano Carrier Board Placement – Top View .....	5
Figure 1-5.	Jetson Orin Nano Carrier Board Placement – Bottom View.....	6
Figure 3-1.	Expansion Header Connections .....	21
Figure 3-2.	Jack Connector .....	26
Figure 3-3.	PoE Alternative Power Input.....	27
Figure 4-1.	Developer Kit Carrier Board Mechanical Dimensions.....	29
Figure 4-2.	Developer Kit Mechanical Dimensions .....	30
Figure 5-1.	Power Diagram.....	31

# List of Tables

Table 2-1.	USB 3.2 Type C Connector Pin Description – J5.....	7
Table 2-2.	USB 3.2 Type A Connector Pin Descriptions – J6.....	8
Table 2-3.	USB 3.2 Type A Connector Pin Description – J7 .....	9
Table 2-4.	Ethernet RJ45 Connector Pin Description – J15.....	10
Table 2-5.	DisplayPort Connector Pin Description – J8 .....	11
Table 2-6.	M.2 Key E Expansion Slot Pin Description – J10.....	12
Table 2-7.	M.2 Key M Expansion Slot Pin Description – J11 (x4 PCIe).....	14
Table 2-8.	M.2 Key M Expansion Slot Pin Description – J24 (x2 PCIe).....	16
Table 3-1.	Camera #0 Connector Pin Description – J20 .....	19
Table 3-2.	Camera #1 Connector Pin Description – J21 .....	20
Table 3-3.	Expansion Header Pin Description – J12.....	22
Table 3-4.	Button Header Description – J14 .....	24
Table 3-5.	Optional CAN Header Pin Description – J17 .....	25
Table 3-6.	Fan Connector Pin Description – J13.....	25
Table 3-7.	RTC Backup Batter Connector Pin Description – J3 .....	26
Table 3-8.	DC Jack Pin Description – J16.....	27
Table 3-9.	PoE Header – J19 .....	27
Table 3-10.	PoE Backpower Header – J18.....	28
Table 5-1.	Interface Power Supply Allocation.....	32
Table 5-2.	Interface Supply Current Capabilities.....	32
Table 5-3.	Supply Current Capabilities per Connector per Supply .....	33

---

# Chapter 1. Introduction

This specification contains recommendations and guidelines for engineers to follow to create modules for the expansion connectors on the NVIDIA® Jetson Orin™ Nano carrier board. As well as understand the capabilities of the other dedicated interface connectors and associated power solutions on the platform.

The Jetson Orin Nano carrier board is ideal for software development within the Linux environment. Standard connectors are used to access Jetson Orin Nano features and interfaces, enabling a highly flexible and extensible development platform. Go to <https://developer.nvidia.com/embedded/develop> or contact your NVIDIA representative for access to software updates and the developer SDK supporting the OS image and host development platform that you want to use. The developer SDK includes an OS image that you will load onto your Jetson Orin Nano device, supporting documentation, and code samples to help you get started.

The Jetson Orin Nano carrier board supports all the Jetson Orin Nano Series and Jetson Orin NX Series modules.



**Caution:** ALWAYS CONNECT JETSON ORIN NANO and ALL EXTERNAL PERIPHERAL DEVICES BEFORE CONNECTING THE POWER SUPPLY TO THE AC POWER JACK. Connecting a device while powered on may damage the developer kit carrier board, Jetson Orin Nano, or peripheral device. In addition, the carrier board should be powered down and the power removed before plugging or unplugging devices or add-on modules into the headers. Wait for the red power VDD\_IN LED to turn off or wait for 5 minutes if your system does not have a power LED. This includes the Jetson Orin Nano module, the camera connector, the M.2 connector, and the other expansion headers.

The Jetson Orin Nano developer board contains ESD-sensitive parts. Always use appropriate anti-static and grounding techniques when working with the system. Failure to do so can result in ESD discharge to sensitive pins, and irreparably damage your Jetson Orin Nano board. NVIDIA will not replace units that have been damaged due to ESD discharge.



**Note:** The developer kit carrier board has been modified to only support 5V to the module. The MODULE\_ID signal is not pulled up on the carrier board. This means that regardless of the capability of the module, VDD\_IN will be 5V only. Custom carrier boards can still be designed to support 5V and 19V and use the MODULE\_ID to identify a 5V vs. 19V Input. Orin NX can still operate up to the full 20W-25W with the 5V VDD\_IN.

## 1.1 Jetson Orin Nano Module Feature List

The following is a list of features for the Jetson Orin Nano module.

- > Applications processor (AP)
  - NVIDIA Orin™
- > Memory
  - 8 GB 128-bit wide LPDDR5 DRAM (68 GB/s)
  - Micro SD card socket (UHS-1)
- > Networking
  - 10/100/1000 BASE-T Ethernet
- > Advanced power management (APM)
- > Dynamic voltage and frequency scaling
- > Multiple clock and power domains

## 1.2 Carrier Board Feature List

The following is a list of features for the carrier board.

- > Connection to Jetson Orin Nano
  - 260-pin SO-DIMM connector
- > USB
  - USBC: Supports Recovery Mode
  - USB 3.2 (Gen2x1) Hub to 4x Type A (host only)
- > Wired network
  - Gigabit Ethernet (RJ45 connector with LEDs and optional PoE header)
- > Display
  - VESA® DisplayPort™ (DP v1.2 (+MST) and eDP v1.4)
- > Camera connectors
  - 2x 22-position flex connectors
  - CSI (2.5 Gbps per pair): 1, x2 or x4 and 1, x2
  - Camera CLK, I2C, and control
- > M.2 Key E connector
  - PCIe (Gen3) x1 Lane, USB 2.0
  - I2S, UART, I2C
  - Control

- > M.2 Key M connector (x2)
  - #1) PCIe (Gen3) x4 lane, control
  - #2) PCIe (Gen3) x2 lane, control
- > Expansion header
  - 40-pin (2x20) header
  - I2C (x2), SPI (x2), UART
  - I2S, audio clock, GPIOs, PWMs
- > UI and indicators
  - Button header: Power, reset, force recovery, debug UART, Auto-Power-On disable
  - LEDs: Power
- > Miscellaneous
  - Fan connector: 5V, PWM, and tach
  - Optional RTC back-up connector
  - Optional CAN header
- > Power
  - DC Jack: 9-20 V (19V supply provided)
  - Optional Ethernet PoE and back power headers
  - Main 5.0 V Pre-regulator: GS9230 (or A0Z2264)
    - Provides VDD\_IN to module
  - Main 3.3V supply: GS9230 (or A0Z2264)
  - Main 1.8V supply: GS7116S5
  - 3.3V AO (always on) supply: GS7116S5
  - USB VBUS load switches: AP22811AW5-7 (x2)
  - DP 3.3V power switch: APL3552ABI-TRG
- > Developer kit operating temperature range
  - 0°C to 35°C

## 1.3 Jetson Orin Nano Carrier Board Block Diagram

Figure 1-1 through Figure 1-5 show the block diagram and various placement views for Jetson Orin Nano and the carrier board.





Figure 1-3. Jetson Orin Nano – Bottom View (Envelope)

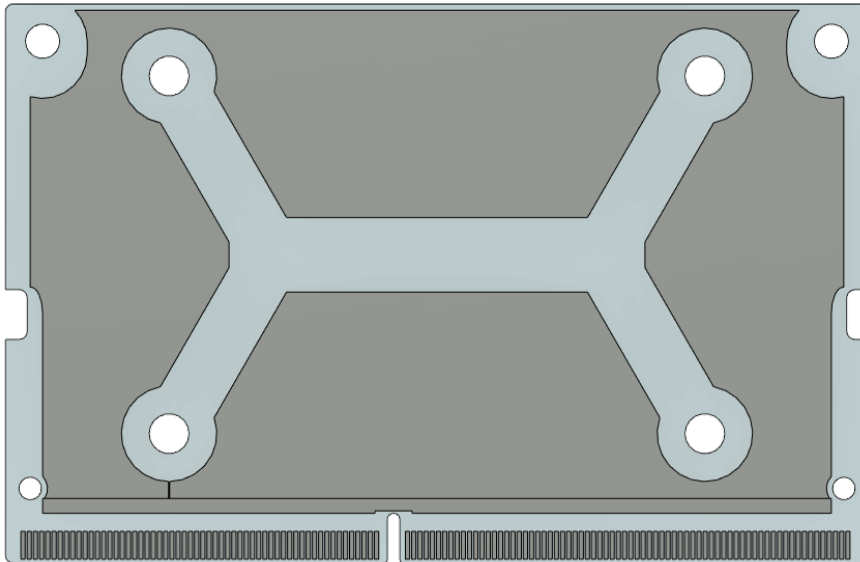
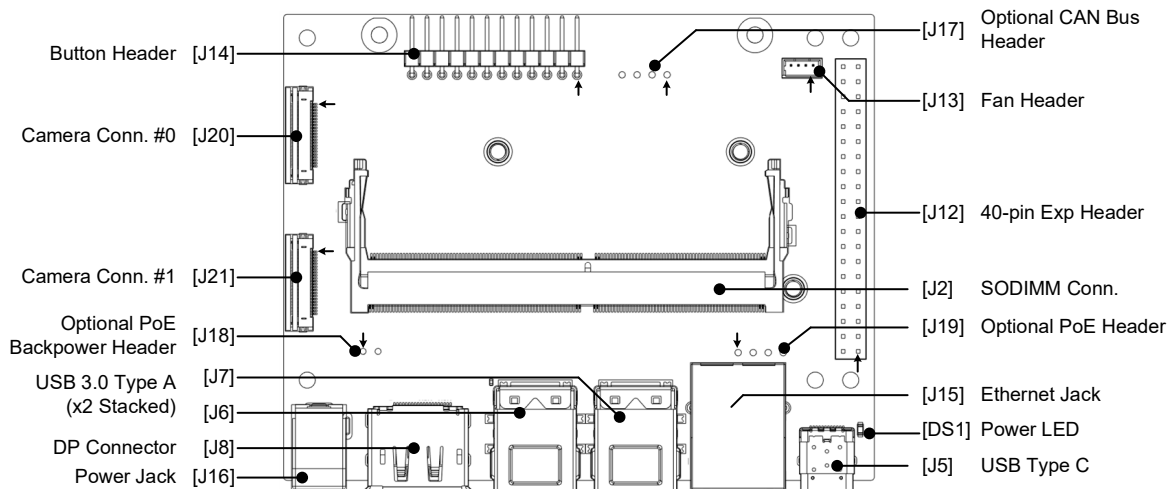
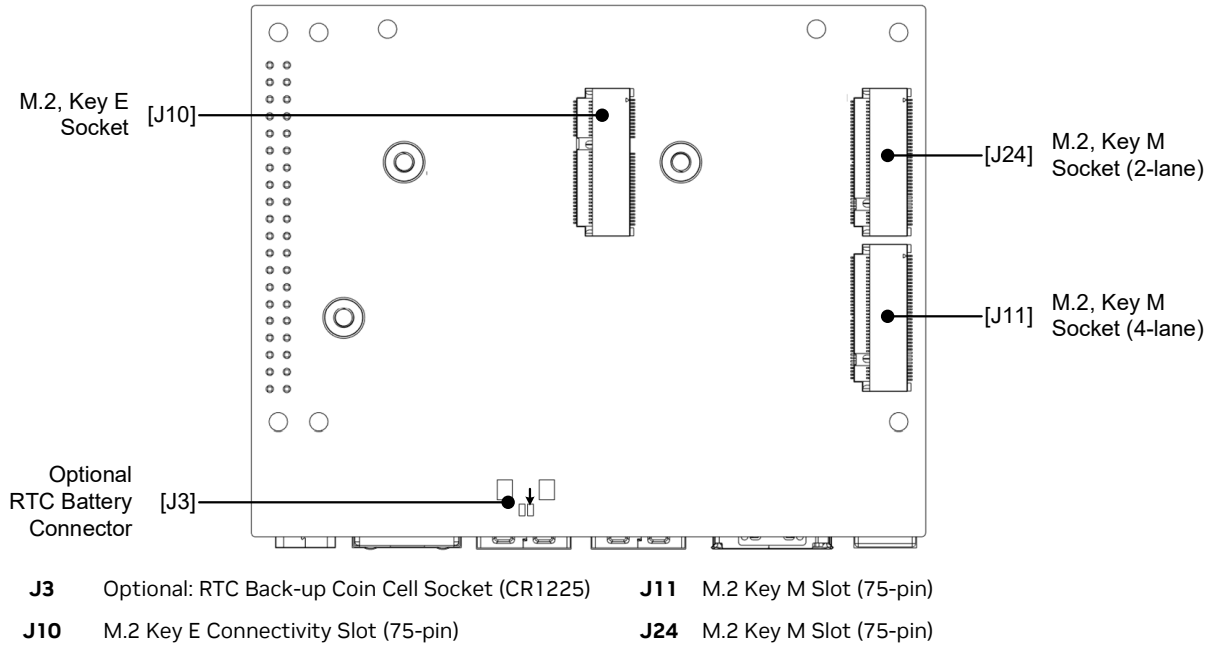

Figure 1-4. Jetson Orin Nano Carrier Board Placement – Top View



<b>J2</b>	Jetson Orin Nano Conn. (SODIMM, 260-pin)	<b>J15</b>	RJ45 Ethernet Socket, 18-pins, RA, Female
<b>J5</b>	USB Type C	<b>J16</b>	Power Jack
<b>J6</b>	USB Type A Dual Stacked Connector	<b>J17</b>	Optional: CAN Bus Header (1x4, 2.54 mm pitch, RA)
<b>J7</b>	USB Type A Dual Stacked Connector	<b>J18</b>	Optional: PoE Backpower Header (1x2, 2.54 mm pitch)
<b>J8</b>	DisplayPort Connector	<b>J19</b>	Optional: PoE Header (1x4, 2.54 mm pitch)
<b>J12</b>	40-pin Expansion Header (2x20, 2.54 mm pitch)	<b>J20</b>	Camera (#0) Connector (22 pos, 0.5 mm pitch)
<b>J13</b>	Fan Header (4-pin, 1.25 mm pitch)	<b>J21</b>	Camera (#1) Connector (22 pos, 0.5 mm pitch)
<b>J14</b>	Button Header (1x12, 2.54 mm pitch, RA)	<b>DS1</b>	Power LED (Green)

Figure 1-5. Jetson Orin Nano Carrier Board Placement – Bottom View



---

# Chapter 2. Jetson Nano Carrier Board Standard Connectors

The Jetson Orin Nano carrier board provides several connectors with industry standard pinouts to support additional functionality beyond what is integrated on the main platform board. This includes:

- > USB 3.2: Type C connector
- > USB 3.2: 2 x Type A stacked connectors
- > Gigabit Ethernet: RJ45 connector
- > DisplayPort connector
- > M.2, Key E socket
- > M.2, Key M socket (4-lane PCIe)
- > M.2, Key M socket (2-lane PCIe)

## 2.1 USB Ports

The carrier board supports five USB connectors. One is a USB 3.2 Type C connector (J5) supporting host, device, and USB Recovery. In addition, there are two, dual stacked USB 3.2 Type A connectors (J6 and J7). Each connector supports host mode only. A load switch supplying VBUS is provided for each of the USB 3.2 ports per stack and is limited to 3A of output current.

Table 2-1. USB 3.2 Type C Connector Pin Description – J5

Pin #	Connector Pin Name	Associated Module Pin Name (See Note 1 and 2)	Module Pin #	Usage/Description	Type/Dir
A1	GND_A	-	-	Ground	Ground
A2	TX1_P	USBSS1_TX_P	G23	USB 3.2 #1 Transmit 1 from mux	Output
A3	TX1_N	USBSS1_TX_N	G22		
A4	-	-	-	USB VBUS_A Power	Power
A5	CC1	-	-	CC 1 from CC Controller	Output
A6	D1_P	USB0_D_P	F12	USB 2.0 #0 Data 1	Bidir

Pin #	Connector Pin Name	Associated Module Pin Name (See Note 1 and 2)	Module Pin #	Usage/Description	Type/Dir
A7	D1_N	USB0_D_N	F13		
A8	SBU1	-	-	Unconnected	-
A9	-	-	-	USB VBUS_A Power	Power
A10	RX2_N	USBSS1_RX_P	C22	USB 3.2 #1 Receive 2 from mux	Input
A11	RX2_P	USBSS1_RX_N	C23		
A12	GND_A	-	-	Ground	Ground
B1	GND_B	-	-	Ground	Ground
B2	TX2_P	USBSS1_TX_P	G23	USB 3.2 #1 Transmit 2 from mux	Output
B3	TX2_N	USBSS1_TX_N	G22		
B4	-	-	-	USB VBUS_A Power	Power
B5	CC2	-	-	CC 2 from CC Controller	Output
B6	D2_P	USB0_D_P	F12	USB 2.0 #0 Data 2	Bidir
B7	D2_N	USB0_D_N	F13		
B8	SBU2	-	-	Unconnected	-
B9	-	-	-	USB VBUS_A Power	Power
B10	RX1_N	USBSS1_RX_P	C22	USB 3.2 #1 Receive 1 from mux	Input
B11	RX1_P	USBSS1_RX_N	C23		
B12	GND_B	-	-	Ground	Ground

Notes:

1. USB 3.2 module pin names are using the Orin NX and Orin Nano function names.
2. The module pins for the USB 3.2 ports are not directly connected to the USB connector pins but are routed through a multiplexer.
3. In the Type/Dir column, Output is to USB connectors. Input is from USB connectors. Bidir is for bidirectional signals.

Legend	Ground	Power	Reserved

Table 2-2. USB 3.2 Type A Connector Pin Descriptions – J6

Pin #	Module Pin Name (see Note 1 and 2)	Module Pin #	Usage/Description	Type/Dir
<b>USB 3.0 Type A (2)</b>				
1	-	-	VBUS Supply	Power
2	USB1_D_N		USB 2.0 #2 Data from hub	Bidir
3	USB1_D_P			
4	-	-	Ground	Ground
5	USBSS0_RX_N	161	USB 3.1 Receive #2 Data from hub	Input

Pin #	Module Pin Name (see Note 1 and 2)	Module Pin #	Usage/Description	Type/Dir
6	USBSS0_RX_P	163		
7	-	-	Ground	Ground
8	USBSS0_TX_N	166	USB 3.1 Transmit #2 Data from hub	Output
9	USBSS0_TX_P	168		
<b>USB 3.0 Type A (1)</b>				
10	-	-	VBUS Supply	Power
11	USB1_D_N	115	USB 2.0 Data #1 Data from hub	Bidir
12	USB1_D_P	117		
13	-	-	Ground	Ground
14	USBSS0_RX_N	161	USB 3.1 Receive #1 Data from hub	Input
15	USBSS0_RX_P	163		
16	-	-	Ground	Ground
17	USBSS0_TX_N	166	USB 3.1 Transmit #1 Data from hub	Output
18	USBSS0_TX_P	168		

**Notes:**

1. USB 3.2 module pin names are using the Orin NX and Orin Nano function names.
2. The module pin names not directly connected to the USB connector pins but are routed to the input of the USB hub.
3. In the Type/Dir column, Output is to USB connectors. Input is from USB connectors. Bidir is for bidirectional signals.

<b>Legend</b>	Ground	Power	Reserved
---------------	--------	-------	----------

**Table 2-3. USB 3.2 Type A Connector Pin Description – J7**

Pin #	Module Pin Name (see Note 1 and 2)	Module Pin #	Usage/Description	Type/Dir
<b>USB 3.0 Type A (2)</b>				
1	-	-	VBUS Supply	Power
2	USB1_D_N	115	USB 2.0 #4 Data from hub	Bidir
3	USB1_D_P	117		
4	-	-	Ground	Ground
5	USBSS0_RX_N	161	USB 3.1 Receive #4 Data from hub	Input
6	USBSS0_RX_P	163		
7	-	-	Ground	Ground
8	USBSS0_TX_N	166	USB 3.1 Transmit #4 Data from hub	Output
9	USBSS0_TX_P	168		

Pin #	Module Pin Name (see Note 1 and 2)	Module Pin #	Usage/Description	Type/Dir
<b>USB 3.0 Type A (1)</b>				
10	-	-	VBUS Supply	Power
11	USB1_D_N	115	USB 2.0 Data #3 Data from hub	Bidir
12	USB1_D_P	117		
13	-	-	Ground	Ground
14	USBSS0_RX_N	161	USB 3.1 Receive #3 Data from hub	Input
15	USBSS0_RX_P	163		
16	-	-	Ground	Ground
17	USBSS0_TX_N	166	USB 3.1 Transmit #3 Data from hub	Output
18	USBSS0_TX_P	168		

**Notes:**

1. USB 3.2 module pin names are using the Orin NX and Orin Nano function names.
2. The module pin names not directly connected to the USB connector pins but are routed to the input of the USB hub.
3. In the Type/Dir column, Output is to USB connectors. Input is from USB connectors. Bidir is for bidirectional signals.

<b>Legend</b>	Ground	Power	Reserved
---------------	--------	-------	----------

## 2.2 Gigabit Ethernet

The carrier board implements an RJ45 connector (J15) along with the necessary magnetics device.

**Table 2-4. Ethernet RJ45 Connector Pin Description – J15**

Pin #	Module Pin Name	Module Pin #	Usage/Description	Type/Dir
1	GPE_MDIO_P	186	Gigabit Ethernet MDI 0+	Bidir
2	GPE_MDIO_N	184	Gigabit Ethernet MDI 0-	Bidir
3	GPE_MDI1_P	192	Gigabit Ethernet MDI 1+	Bidir
4	-	-	MCT	-
5	-	-	MCT	-
6	GPE_MDI1_N	190	Gigabit Ethernet MDI 1-	Bidir
7	GPE_MDI2_P	198	Gigabit Ethernet MDI 2+	Bidir
8	GPE_MDI2_N	196	Gigabit Ethernet MDI 2-	Bidir
9	GPE_MDI3_P	204	Gigabit Ethernet MDI 3+	Bidir

Pin #	Module Pin Name	Module Pin #	Usage/Description	Type/Dir
10	GPE_MDI3_N	202	Gigabit Ethernet MDI 3-	Bidir
11	-	-	Power-Over-Ethernet	Power
12				
13				
14				
15	-	-	Green LED Anode	Input
16	GBE_LED_LINK	188	Green LED Cathode. On for 1,000 Mbps link. Off for 10/100Mbps.	Output
17	-	-	Yellow LED Anode	Input
18	GBE_LED_ACT	194	Yellow LED Cathode. On indicates activity.	Output
19	-	-	Shield Ground	Ground
20				

Note: In the Type/Dir column, Output is to RJ45 connector. Input is from RJ45 connector. Bidir is for bidirectional signals.

<b>Legend</b>	Ground	Power	Reserved
---------------	--------	-------	----------

## 2.3 DisplayPort

A DisplayPort (DP) connector (J8) is provided. Dual mode is supported.

Table 2-5. DisplayPort Connector Pin Description – J8

Pin #	Module Pin Name	Module Pin #	Usage/Description	Type/Dir
1	DPO_TXD0_P	41	DP Lane 0+	Output
2	-	-	Ground	Ground
3	DPO_TXD0_N	39	DP Lane 0-	Output
4	DPO_TXD1_P	47	DP Lane 1+	Output
5	-	-	Ground	Ground
6	DPO_TXD1_N	45	DP Lane 1-	Output
7	DPO_TXD2_P	53	DP Lane 2+	Output
8	-	-	Ground	Ground
9	DPO_TXD2_N	51	DP Lane 2-	Output
10	DPO_TXD3_P	59	DP Lane 3+	Output
11	-	-	Ground	Ground
12	DPO_TXD3_N	57	DP Lane 3-	Output

Pin #	Module Pin Name	Module Pin #	Usage/Description	Type/Dir
13	-	-	MODE to support Dual-role mode. Connects from DP connector to PI3AUX221ZTAEX device to select between DP or HDMI mode.	Input
14	-	-	CEC_DP: Not used – pulled to GND through 1 Mohm resistor	Unused
15	DPO_AUX_N	90	DisplayPort Auxiliary Channel 0-	Bidir
16	-	-	Ground	Ground
17	DPO_AUX_P	92	DisplayPort Auxiliary Channel 0+	Bidir
18	DPO_HPD	88	HDMI™ Hot Plug Detect	Input
19	-	-	Power Return (Ground)	Ground
20	-	-	+3.3 V	Power

Note: In the Type/Dir column, Output is to DP connector. Input is from DP connector. Bidir is for bidirectional signals.

<b>Legend</b>	Ground	Power	Reserved
---------------	--------	-------	----------

## 2.4 M.2 Key E Expansion Slot

The Jetson Orin Nano carrier board includes a M.2, Key E Slot Mini-PCIe Expansion slot (J10). This includes interface options for WiFi/BT including PCIe (x1), USB 2.0, UART, I2S, and I2C optional.

 **Notes:**

- > The Jetson Orin Nano Developer Kit carrier board will only support single sided M.2 Key E modules.
- > Stuffing resistors for connecting I2C2 to pins 58 and 60 of the M.2 Key E connector are not installed by default. If I2C is required, 0Ω resistors can be installed at locations R106 and R107. Care should be taken as some M.2 cards can cause conflicts with other devices connected to the I2C interface.

Table 2-6. M.2 Key E Expansion Slot Pin Description – J10

Pin #	Module Pin Name	Module Pin #	Usage/Description	Type/Dir	Pin #	Module Pin Name	Module Pin #	Usage/Description	Type/Dir
1	-	-	Ground	Ground	-	-	-	No Pin	-
3	USB2_D_P	123	USB 2.0 Data	Bidir	2	-	-	Main 3.3V Supply	Power
5	USB2_D_N	121			4	-	-		
7	-	-	Ground	Ground	6	-	-	Unused	Unused
9	-	-	Unused	Unused	8	I2S1_CLK	226	I2S #1 Clock	Bidir, 1.8V



Jetson Nano Carrier Board Standard Connectors

Pin #	Module Pin Name	Module Pin #	Usage/Description	Type/Dir	Pin #	Module Pin Name	Module Pin #	Usage/Description	Type/Dir
11					10	I2S1_FS	224	I2S #1 Left/Right Clock	Bidir, 1.8V
13					12	I2S1_DIN	222	I2S #1 Data In	Input, 1.8V
15					14	I2S1_DOUT	220	I2S #1 Data Out	Bidir, 1.8V
17					16	-	-	Unused	Unused
19					18	-	-	Ground	Ground
21					20	GPIO02	124	Bluetooth #2 Wake AP	Input, 3.3V
23					22	UART0_RXD	101	UART #0 Receive	Input, 1.8V
25					24				
27	-	-	Key	Unused	26	-	-	Key	Unused
29					28				
31					30				
33	-	-	Ground	Ground	32	UART0_TXD	99	UART #0 Transmit	Output, 1.8V
35	PEX1_TX0_P	174	PCIe #1 Transmit Lane 0	Output	34	UART0_CTS*	105	UART #0 Clear to Send	Input, 1.8V
37	PEX1_TX0_N	172			36	UART0_RTS*	103	UART #0 Request to Send	Output, 1.8V
39	-	-	Ground	Ground	38				
41	PEX1_RX0_P	169	PCIe #1 Receive Lane 0	Input	40				
43	PEX1_RX0_N	167			42				
45	-	-	Ground	Ground	44			Unused	Unused
47	PEX1_CLK_P	175	PCIe #1 Reference clock	Output	46				
49	PEX1_CLK_N	173			48				
51	-	-	Ground	Ground	50	CLK_32K_OUT	210	Suspend Clock (32 KHz)	Output, 3.3V
53	PEX1_CLKREQ*	182	PCIe #1 Clock Request	Bidir, 3.3V	52	PEX0_RST*	183	PCIe #0 Reset	Output, 3.3V
55	PEX_WAKE*	179	PCIe Wake	Input, 3.3V	54	GPIO3	126	BT Enable	Output, 3.3V
57	-	-	Ground	Ground	56	GPIO5	128	Wi-Fi Disable	Output, 3.3V
59			Unused	Unused	58	I2C2_SDA	234	General I2C #2 (optional)	Bidir/OD, 1.8V
61					60	I2C2_SCL	232		
63	-	-	Ground	Ground	62	GPIO10	212	M.2, Key E Connector Alert	Input, 1.8V

Pin #	Module Pin Name	Module Pin #	Usage/Description	Type/Dir	Pin #	Module Pin Name	Module Pin #	Usage/Description	Type/Dir
65	-	-	Unused	Unused	64	-	-	Unused	Unused
67	-	-	Unused	Unused	66	-			
69	-	-	Ground	Ground	68	-			
71	-	-	Unused	Unused	70	-			
73	-	-	Unused	Unused	72	-	Main 3.3V Supply	Power	
75	-	-	Ground	Ground	74	-			

Note: In the Type/Dir column, Output is to M.2 module. Input is from M.2 module. Bidir is for bidirectional signals.

<b>Legend</b>	Ground	Power	Reserved
---------------	--------	-------	----------

## 2.5 M.2 Key M Expansion Slot

The carrier board includes two M.2, Key M Slots for NVMe storage (J11 and J24). The M.2, Key M slot J11 supports PCIe (x4), Gen4. The M.2, Key M slot J24 supports PCIe (x2), Gen4.

 **Notes:**

- > Jetson Orin Nano modules supports only up to Gen3 PCIe, and Jetson Orin NX modules support up to Gen4 PCIe
- > The Jetson Orin Nano Developer Kit carrier board will only support single sided M.2 Key M modules.

Table 2-7. M.2 Key M Expansion Slot Pin Description – J11 (x4 PCIe)

Pin #	Module Pin Name	Module Pin #	Usage/Description	Type/Dir Default	Pin #	Module Pin Name	Module Pin #	Usage/Description	Type/Dir Default
1	-	-	Ground	Ground	2	-	-	Main 3.3V Supply	Power
3	-	-	Ground	Ground	4	-	-		
5	PCIE0_RX3_N	155	PCIe IF #0 Lane 3 Receive	Input	6	-	-	Unused	Unused
7	PCIE0_RX3_P	157							
9	-	-	Ground	Ground	10	-	-		
11	PCIE0_TX3_N	154	PCIe IF #0 Lane 3 Transmit	Output	12	-	-	Main 3.3V Supply	Power
13	PCIE0_TX3_P	156							
15	-	-	Ground	Ground	16	-	-		
17	PCIE0_RX2_N	149	PCIe IF #0 Lane 2 Receive	Input	18	-	-	Unused	Unused
19	PCIE0_RX2_P	151							
					20	-	-	Unused	Unused

Pin #	Module Pin Name	Module Pin #	Usage/Description	Type/Dir Default	Pin #	Module Pin Name	Module Pin #	Usage/Description	Type/Dir Default
21	-	-	Ground	Ground	22				
23	PCIE0_TX2_N	148	PCIe IF #0 Lane 2 Transmit	Output	24				
25	PCIE0_TX2_P	150			26				
27	-	-	Ground	Ground	28				
29	PCIE0_RX1_N	137	PCIe IF #0 Lane 1 Receive	Input	30				
31	PCIE0_RX1_P	139			32				
33	-	-	Ground	Ground	34				
35	PCIE0_TX1_N	140	PCIe IF #0 Lane 1 Transmit	Output	36				
37	PCIE0_TX1_P	142			38				
39	-	-	Ground	Ground	40				
41	PCIE0_RX0_N	131	PCIe IF #0 Lane 0 Receive	Input	42			Unused	Unused
43	PCIE0_RX0_P	133			44	GPIO10	212	M.2 Key M Alert	Input, 1.8V
45	-	-	Ground	Ground	46				
47	PCIE0_TX0_N	134	PCIe IF #0 Lane 0 Transmit	Output	48			Unused	Unused
49	PCIE0_TX0_P	136			50	PEX0_RST*	181	PCIe IF #0 Reset	Output, 3.3V
51	-	-	Ground	Ground	52	PEX0_CLKREQ*	180	PCIe IF #0 Clock Request	Input, 3.3V
53	PCIE0_CLK_N	160	PCIe IF #0 Reference Clock	Output	54	PEX_WAKE*	179	PCIe Wake (Level Shifted from 3.3V to 1.8V)	Input, 3.3V
55	PCIE0_CLK_P	162			56				Unused
57	-	-	Ground	Ground	58				
59					60				
61					62				
63			Unused (Key)	Unused	64			Unused (Key)	Unused
65					66				
67			Unused	Unused	68			32 KHz Suspend Clock	Output, 3.3V
69					70				
71					72			Main 3.3V Supply	Power
73			Ground	Ground	74				
75								No Pin	-

Note: In the Type/Dir column, Output is to M.2 module. Input is from M.2 Module. Bidir is for bidirectional signals.

**Legend**

Ground	Power	Reserved
--------	-------	----------

**Table 2-8. M.2 Key M Expansion Slot Pin Description – J24 (x2 PCIe)**

Pin #	Module Pin Name	Module Pin #	Usage/Description	Type/Dir Default	Pin #	Module Pin Name	Module Pin #	Usage/Description	Type/Dir Default
1	-	-	Ground	Ground	2	-	-	Main 3.3V Supply	Power
3	-	-	Ground	Ground	4	-	-	Main 3.3V Supply	Power
5	-	-	Unused	Unused	6	-	-	Unused	Unused
7	-	-	Unused	Unused	8	-	-	Unused	Unused
9	-	-	Ground	Ground	10	-	-	Unused	Unused
11	-	-	Unused	Unused	12	-	-	Main 3.3V Supply	Power
13	-	-	Unused	Unused	14	-	-	Main 3.3V Supply	Power
15	-	-	Ground	Ground	16	-	-	Main 3.3V Supply	Power
17	-	-	Unused	Unused	18	-	-	Unused	Unused
19	-	-	Unused	Unused	20	-	-	Unused	Unused
21	-	-	Ground	Ground	22	-	-	Unused	Unused
23	-	-	Unused	Unused	24	-	-	Unused	Unused
25	-	-	Unused	Unused	26	-	-	Unused	Unused
27	-	-	Ground	Ground	28	-	-	Unused	Unused
29	PCIE2_RX1_N	58	PCIe IF #2 Lane 1 Receive	Input	30	-	-	Unused	Unused
31	PCIE2_RX1_P	60			32	-	-		
33	-	-	Ground	Ground	34	-	-	Unused	Unused
35	PCIE2_TX1_N	64	PCIe IF #2 Lane 1 Transmit	Output	36	-	-	Unused	Unused
37	PCIE2_TX1_P	66			38	-	-		
39	-	-	Ground	Ground	40	-	-	Unused	Unused
41	PCIE2_RX0_N	40	PCIe IF #2 Lane 0 Receive	Input	42	-	-	Unused	Unused
43	PCIE2_RX0_P	42			44	GPIO10	212		
45	-	-	Ground	Ground	46	-	-	Unused	Unused
47	PCIE2_TX0_N	46	PCIe IF #2 Lane 0 Transmit	Output	48	-	-	Unused	Unused
49	PCIE2_TX0_P	48			50	PEX2_RST*	219	PCIe IF #0 Reset	Output, 3.3V
51	-	-	Ground	Ground	52	PEX2_CLKREQ*	221	PCIe IF #0 Clock Request	Input, 3.3V
53	PCIE2_CLK_N	52	PCIe IF #2 Reference Clock	Output	54	PEX_WAKE*	179	PCIe Wake (Level Shifted from 3.3V to 1.8V)	Input, 3.3V
55	PCIE2_CLK_P	54			56	-	-	Unused	Unused
57	-	-	Ground	Ground	58	-	-	Unused	Unused
59	-	-	Unused (Key)	Unused	60	-	-	Unused (Key)	Unused

Pin #	Module Pin Name	Module Pin #	Usage/Description	Type/Dir Default	Pin #	Module Pin Name	Module Pin #	Usage/Description	Type/Dir Default
61					62				
63					64				
65					66				
67	-	-	Unused	Unused	68	-	-	32 KHz Suspend Clock	Output, 3.3V
69					70				
71					72			Main 3.3V Supply	Power
73	-	-	Ground	Ground	74				
75								-No Pin	-

**Notes:**

1. PCIe 2 module pin names are using the Orin NX and Orin Nano function names.
2. In the Type/Dir column, Output is to M.2 module. Input is from M.2 Module. Bidir is for bidirectional signals.

<b>Legend</b>	Ground	Power	Reserved
---------------	--------	-------	----------

---

# Chapter 3. Carrier Board Custom Expansion IF Connections

The Jetson Orin Nano carrier board supports several expansion headers and connectors that have custom pinouts. The following lists the headers and connectors that have custom pinouts.

- > Jetson Orin Nano Module Connector, 260-pin, SO-DIMM, 1.27 mm pitch
- > Camera Connectors (x2), 22 position, Flex Connector, 0.5 mm pitch
- > 40-Pin Expansion Header, 2x20, 2.54 mm pitch
- > Button Header, 2x4, 2.54 mm pitch
- > Optional CAN Bus header
- > Fan Connector, 4-pin, 1.25 mm pitch
- > Optional real-time-clock (RTC) back-up connector
- > DC Power Jack
- > Optional Power-over Ethernet (PoE) header, 1x4, 2.54 mm pitch
- > Optional PoE backpower header, 1x, 2.54 mm pitch

## 3.1 Jetson Orin Nano Module Connector

The carrier board interfaces to the Jetson Orin Nano module using a 260-pin SODIMM connector (J2). The carrier board has a TE Connectivity 2309413-1 connector. This interfaces with the Jetson Orin Nano edge fingers. The connector pinout can be found in the *Jetson Orin Nano Product Design Guide*.

## 3.2 Camera Connector

The Jetson Orin Nano carrier board includes two 22-position flex (0.5 mm pitch) camera connectors (J20 and J219). The connector used on the carrier board is a Molex Japan Part #54548-2272.

The connectors support the following.

- > J20: CSI 1 x2 lane
- > J21: CSI 1 x2 lane or 1 x4 lane
- > Both J20/J21: C
  - CAM\_I2C, clock, and control GPIOs for the camera
  - 3.3V Supply

**Table 3-1. Camera #0 Connector Pin Description – J20**

Pin #	Module Pin Name	Module Pin #	Usage/Description	Type/Dir
1	–	–	+3.3V	Power
2	CAM_I2C_SDA	215	Camera I2C. 2.2 kΩ pull-ups on module. The module CAM_I2C pins connect to an I2C mux. The camera connector #0 (J20) receives the I2C from the mux (first output). The I2C signals on the camera side of the mux have 1 kΩ pull-ups.	Bidir, 3.3V
3	CAM_I2C_SCL	213		Output, 3.3V
4	–	–	Ground	Ground
5	CAM0_MCLK	116	Camera #0 Primary Clock	Output, 1.8V
6	CAM0_PWDN	114	Camera #0 Power-down	Output, 1.8V
7	–	–	Ground	Ground
8	CSI0_D1_P	18	CSI 0 Data 1	Input
9	CSI0_D1_N	16		
10	–	–	Ground	Ground
11	CSI0_D0_P	6	CSI 0 Data 0	Input
12	CSI0_D0_N	4		
13	–	–	Ground	Ground
14	CSI1_CLK_P	11	CSI 0 Clock	Input
15	CSI1_CLK_N	9		
16	–	–	Ground	Ground
17	CSI1_D1_P	17	CSI 1 Data 1	Input
18	CSI1_D1_N	15		
19	–	–	Ground	Ground
20	CSI1_D0_P	5	CSI 1 Data 0	Input
21	CSI1_D0_N	3		
22	–	–	Ground	Ground

**Note:** In the Type/Dir column, Output is to camera module. Input is from camera module. Bidir is for bidirectional signals.

Legend	Ground	Power	Reserved

Table 3-2. Camera #1 Connector Pin Description – J21

Pin #	Module Pin Name	Module Pin #	Usage/Description	Type/Dir
1	-	-	+3.3V	Power
2	CAM_I2C_SDA	215	Camera I2C. 2.2 kΩ pull-ups on module. The module CAM_I2C pins connect to an I2C mux. The camera connector #1 (J21) receives the I2C from the mux (second output). The I2C signals on the camera side of the mux have 1 kΩ pull-ups.	Bidir, 3.3V
3	CAM_I2C_SCL	213		Output, 3.3V
4	-	-	Ground	Ground
5	CAM1_MCLK	122	Camera #0 Primary Clock	Output, 1.8V
6	CAM1_PWDN	120	Camera #0 Power-down	Output, 1.8V
7	-	-	Ground	Ground
8	CSI3_D1_P	35	CSI 3 Data 1	Input
9	CSI3_D1_N	33		
10	-	-	Ground	Ground
11	CSI3_D0_P	23	CSI 3 Data 0	Input
12	CSI3_D0_N	21		
13	-	-	Ground	Ground
14	CSI2_CLK_P	30	CSI 2 Clock	Input
15	CSI2_CLK_N	28		
16	-	-	Ground	Ground
17	CSI2_D1_P	36	CSI 2 Data 1	Input
18	CSI2_D1_N	34		
19	-	-	Ground	Ground
20	CSI2_D0_P	24	CSI 2 Data 0	Input
21	CSI2_D0_N	22		
22	-	-	Ground	Ground

Note: In the Type/Dir column, Output is to camera module. Input is from camera module. Bidir is for bidirectional signals.

## Legend

Ground	Power	Reserved
--------	-------	----------



## 3.3 40-Pin Expansion Header

The Jetson Orin Nano carrier board includes a 40-pin (2x20, 2.54 mm pitch) expansion header (J12). The connector used on the carrier board is an Astron Technology (Part # 27-0169H-220-1G-H).

The expansion connector includes various audio and control interfaces including:

- > I2S
- > Audio (AU) clock
- > I2C (x2)
- > SPI (x2)
- > UART
- > GPIOs (x3 – See notes)



### Notes:

- > All the signals on the expansion header use 3.3V levels.
- > All the interface signal pins (I2S, I2C, SPI, UART, and AU clock) can also be configured as GPIOs.
- > Any pull-up or pull-down resistors on the signals (except I2C) must be weak (limited to >50 kΩ).

Figure 3-1. Expansion Header Connections

3.3V	1	2	5.0V
I2C1_SDA	3	4	5.0V
I2C1_SCL	5	6	GND
GPIO09	7	8	UART1_TXD
GND	9	10	UART1_RXD
UART1_RTS*	11	12	I2S0_SCLK
SPI1_SCK	13	14	GND
GPIO12	15	16	SPI1_CS1*
3.3V	17	18	SPI1_CS0*
SPI0_MOSI	19	20	GND
SPI0_MISO	21	22	SPI1_MISO
SPI0_SCK	23	24	SPI0_CS0*
GND	25	26	SPI0_CS1*
I2C0_SDA	27	28	I2C0_SCL
GPIO01	29	30	GND
GPIO11	31	32	GPIO07
GPIO13	33	34	GND
I2S0_FS	35	36	UART1_CTS*
SPI1_MOSI	37	38	I2S0_DIN
GND	39	40	I2S0_DOUT

Table 3-3. Expansion Header Pin Description – J12

Header Pin #	Module Pin Name	Module Pin #	SoC Pin Name	Default Usage / Description	Alternate Functionality	Type/ Dir	Pin Drive or Power Pin Max Current	SoC GPIO Port #	Power-on Default	PU/PD on Module	Notes
1	-	-	-	Main 3.3V Supply	-	Power (input)	1A	-	-	-	1
2	-	-	-	Main 5.0V Supply	-	Power (input/output)	1A	-	-	-	1
3	I2C1_SDA	191	GP16_I2C8_DAT	I2C #1 Data	-	Bidir OD	±2 mA	PDD.02	z	2.2KΩ PU	2
4	-	-	-	Main 5.0V Supply	-	Power	1A	-	-	-	-
5	I2C1_SCL	189	GP15_I2C8_CLK	I2C #1 Clock	-	Bidir OD	±2 mA	PDD.01	z	2.2KΩ PU	2
6	-	-	-	Ground	-	Ground	-	-	-	-	-
7	GPIO09	211	GP167	GPIO	Audio Primary Clock	Bidir/Output	±20uA	PAC.06	pd		3
8	UART1_TXD	203	GP70_UART1_TXD_BOOT2_STRAP	UART #1 Transmit	GPIO	Output/Bidir	±20uA	PR.02	pd		3
9	-	-	-	Ground	-	Ground	-	-	-	-	-
10	UART1_RXD	205	GP71_UART1_RXD	UART #1 Receive	GPIO	Input/Bidir	±20uA	PR.03	pd		3
11	UART1_RTS*	207	GP72_UART1_RTS_N	GPIO	UART #2 Request to Send	Bidir/Output	±20uA	PR.04	pd		3
12	I2S0_SCLK	199	GP122	GPIO	Audio I2S #0 Clock	Bidir	±20uA	PH.07	pd		3
13	SPI1_SCK	106	GP36_SPI3_CLK	GPIO	SPI #1 Shift Clock	Bidir/Output	±20uA	PY.00	pd		3
14	-	-	-	Ground	-	Ground	-	-	-	-	-
15	GPIO12	218	GP88_PWM1	GPIO	-	Bidir	±20uA	PN.01	z		3
16	SPI1_CSI1*	112	GP40_SPI3_CS1_N	GPIO	SPI #1 Chip Select #1	Bidir/Output	±20uA	PY.04	z		3
17	-	-	-	Main 3.3V Supply	-	Power	1A	-	-	-	1
18	SPI1_CSI0*	110	GP39_SPI3_CS0_N	GPIO	SPI #0 Chip Select #0	Bidir/Output	±20uA	PZ.06	z		3
19	SPI0_MOSI	89	GP49_SPI1_MOSI	GPIO	SPI #0 Primary Out/Secondary In	Bidir/Output	±20uA	PZ.05	pd		3
20	-	-	-	Ground	-	Ground	-	-	-	-	-
21	SPI0_MISO	93	GP48_SPI1_MISO	GPIO	SPI #0 Primary In/Secondary Out	Bidir/Input	±20uA	PZ.04	pd		3
22	SPI1_MISO	108	GP37_SPI3_MISO	GPIO	SPI #1 Primary In/Secondary Out	Bidir/Input	±20uA	PY.01	pd		3
23	SPI0_SCK	91	GP47_SPI1_CLK	GPIO	SPI #0 Shift Clock	Bidir/Output	±20uA	PZ.03	pd		3

Carrier Board Custom Expansion IF Connections

Header Pin #	Module Pin Name	Module Pin #	SoC Pin Name	Default Usage / Description	Alternate Functionality	Type/ Dir	Pin Drive or Power Pin Max Current	SoC GPIO Port #	Power-on Default	PU/PD on Module	Notes
24	SPIO_CS0*	95	GP50_SPI1_CS0_N	GPIO	SPI #0 Chip Select #0	Bidir/Output	±20uA	PZ.06	z		3
25	-	-	-	Ground	-	Ground	-	-	-	-	-
26	SPIO_CS1*	97	GP51_SPI1_CS1_N	GPIO	SPI #0 Chip Select #1	Bidir/Output	±20uA	PZ.07	pu		3
27	I2C0_SDA	187	GP14_I2C2_DAT	I2C #0 Data	GPIO	Bidir/OD/Bidir	±2 mA	PDD.00	z	1.5KΩ PU	2
28	I2C0_SCL	185	GP13_I2C2_CLK	I2C #0 Clock	GPIO	Bidir/OD/Bidir	±2 mA	PCC.07	z	1.5KΩ PU	2
29	GPIO01	118	GP65	GPIO	General Purpose Clock #0	Bidir/Output	±20uA	PQ.05	pd		3
30	-	-	-	Ground	-	Ground	-	-	-	-	-
31	GPIO11	216	GP66	GPIO	General Purpose Clock #1	Bidir/Output	±20uA	PQ.06	pd		3
32	GPIO07	206	GP113_PWM7	GPIO	PWM	Bidir/Output	±20uA	PG.06	z		3
33	GPIO13	228	GP115	GPIO	PWM	Bidir/Output	±20uA	PH.00	z		3
34	-	-	-	Ground	-	Ground	-	-	-	-	-
35	I2S0_FS	197	GP125	GPIO	Audio I2S #0 Field Select	Bidir	±20uA	PI.02	pd		3
36	UART1_CTS*	209	GP73_UART1_CTS_N	GPIO	UART #1 Clear to Send	Bidir/Input	±20uA	PR.05	pd		3
37	SPI1_MOSI	104	GP38_SPI3_MOSI	GPIO	SPI #1 Primary Out/Secondary In	Bidir/Output	±20uA	PY.02	pd		3
38	I2S0_DIN	195	GP124	GPIO	Audio I2S #0 Data in	Bidir/Input	±20uA	PI.01	pd		3
39	-	-	-	Ground	-	Ground	-	-	-	-	-
40	I2S0_DOUT	193	GP123	GPIO	Audio I2S #0 Data Out	Bidir/Output	±20uA	PI.00	pd		3

Notes:

1. This is current capability per power pin.
2. These pins are connected to the SoC directly. They are open-drain (either pulled up or driven low by the SoC when configured as outputs). The max drive that meets the data sheet VOL is ±2 mA.
3. These pins connect to TI TXB0108 level translators. Due to the design of these devices, the output drivers are very weak, so they can be overdriven by another connected device output for bidirectional support.
4. In the Type/Dir column, output is to expansion header. Input is from expansion header. Bidir is for bidirectional signals. Where two directions are shown, the first is for the primary function (mostly GPIOs) and the second is for the alternate function.
5. Where the signal direction is input or output in this table (Table 3-3), this matches the typical special function usage (for example, SPI, I2S, and so on). The direction is bidirectional if these are configured as GPIOs.
6. All signals on the 40-pin header are 3.3V levels.

<b>Legend</b>	Ground	Power	Reserved
---------------	--------	-------	----------

## 3.4 Button Header

The Jetson Orin Nano carrier board brings several system signals (power, reset, and force recovery), UART, and Sleep/Wake LED-related signals to a pair of standard 0.254 mm pitch header. The button header is J14.

**Table 3-4. Button Header Description – J14**

Pin #	Module Pin Name	Module Pin #	Usage/Description	Type/Dir Default
1	–	–	PC_LED-: Connects to LED Cathode to indicate System Sleep/Wake (Off when system in sleep mode)	Input, 5V
2	–	–	PC_LED+: Connects to LED Anode (see Pin 1)	Output
3	UART2_RXD (DEBUG)	238	UART #2 Receive	Input, 3.3V
4	UART2_TXD (DEBUG)	236	UART #2 Transmit	Output, 3.3V
5	–	–	AC OK: Connect pins 5 and 6 to disable Auto-Power-On and require power button press.	Input, 3.3V
6	–	–	Auto Power-on disable: Pulled to GND. See Pin 5.	Not applicable
7	–	–	Ground	Ground
8	SYS_RESET*	239	Temporarily connect pins 7 and 8 to reset system	Input, 1.8V
9	–	–	Ground	Ground
10	FORCE_RECOVERY*	214	Connect pins 9 and 10 during power-on to put system in USB Force Recovery mode.	Input, 1.8V
11	–	–	Ground	Ground
12	SLEEP/WAKE*	240	Connect pins 11 and 12 to initiate power-on if Auto-Power-On disabled (Pins 5 and 6 connected).	Input, 5V

**Note:** In the Type/Dir column, Output is to button header. Input is from button header. Bidir is for bidirectional signals.

Legend	Ground	Power	Reserved

## 3.5 Optional CAN Bus Header

The Jetson Orin Nano carrier board includes the footprint for a 4-pin, 2.45 mm pitch header (J17) which supports a CAN bus interface.

Table 3-5. Optional CAN Header Pin Description – J17

Pin #	Module Pin Name	Module Pin #	Usage/Description	Type/Dir Default
1	CAN_TX	145	CAN Bus transmit	Output, 3.3V
2	CAN_RX	143	CAN Bus receive	Input, 3.3V
3	-	-	Ground	Ground
4	-	-	Main 3.3V Supply	Power

Note: In the Type/Dir column, Output is to CAN connector. Input is from CAN connector. Bidir is for bidirectional signals.

Legend	Ground	Power	Reserved

## 3.6 Fan Connector

The Jetson Orin Nano carrier board includes a 4-pin fan header (J13). The connector used is a Singatron Enterprise Co., Ltd., Part # 2WBA2542WVC-F-04PNLBT1N00G.

Table 3-6. Fan Connector Pin Description – J13

Pin #	Module Pin Name	Module Pin #	Usage/Description	Type/Dir Default
1	-	-	Ground	Ground
2	-	-	Main 5.0V Supply	Power
3	GPIO08	208	Fan Tachometer signal	Input, 5V
4	GPIO14	230	Fan Pulse Width Modulation signal	Output, 5V

Note: In the Type/Dir column, Output is to fan connector. Input is from fan connector. Bidir is for bidirectional signals.

Legend	Ground	Power	Reserved

## 3.7 Optional Battery Back-up Coin Cell Holder

The Jetson carrier board has a connector where an RTC backup battery can be connected. This connector (J3) is commonly used on laptop designs. The connector used is a Wison Technologies AC2651-0011-003-HH, 2-pin, 1.25 mm pitch connector.

Table 3-7. RTC Backup Batter Connector Pin Description – J3

Pin #	Associated Module Pin Name	Module Pin #	Usage/Description	Type/Dir
1	PM IC_BBAT	235	RTC backup battery supply	Power
2	-	-	Ground	Ground

Legend

Ground	Power	Reserved
--------	-------	----------

## 3.8 DC Power Jack

The Jetson Orin Nano carrier board uses a DC power jack (J16) to bring in the power from the included DC power supply. The jack used on the carrier board is a Singatron Enterprise part (part #: 2DC-0005D206F). The mating barrel jack connector dimensions are:

- > Barrel length: 9.5 mm
- > Barrel diameter: 5.5 mm
- > Pin receptacle: Accepts 2.5 mm jack pin
- > The center pin is positive (+V)
- > Max current supported is 3.5 A

Figure 3-2. Jack Connector

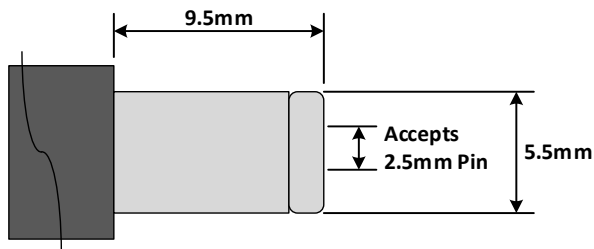

Table 3-8. DC Jack Pin Description – J16

Pin #	Module Pin Name	Module Pin #	Usage/Description	Type/Dir Default
1	-	-	Main DC input supplying DC jack input (9-20 V)	Power
2	-	-	Ground	Ground
3	-	-	Ground	Ground

Legend	Ground	Power	Reserved

## 3.9 Optional Power-Over Ethernet and Backpower Headers

The Jetson Orin Nano carrier board provides an option for an alternate main power input (besides the DC power jack). A 4-pin Power over Ethernet (PoE) header (J19 – 1x4 male, 2.54 mm pitch) brings out the VC power pins of the Ethernet connector. In addition, a 2-pin Backpower header (J18 – 1x2 male, 2.54 mm pitch) provides an alternate path for the input voltage (3 A max). To use this alternate PoE power mechanism, the design will require a power converter to take the high-voltage PoE supply (38 V-60 V) and convert it to the 5 V-20 V input the carrier board requires.

Figure 3-3. PoE Alternative Power Input

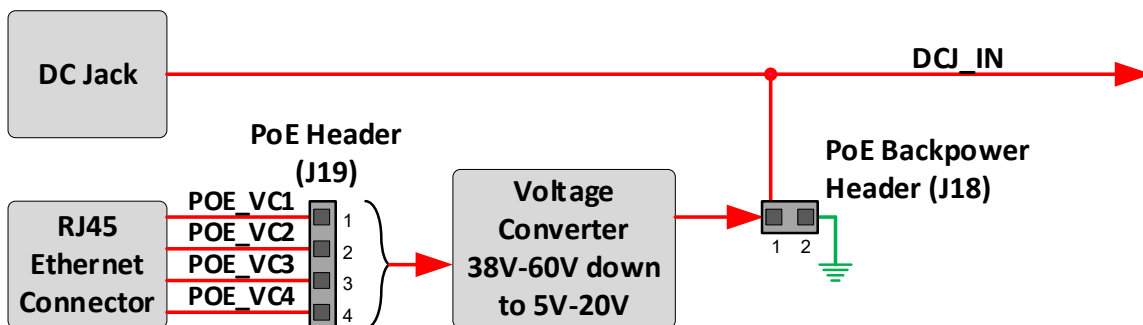

Table 3-9. PoE Header – J19

Pin #	Module Pin Name	Module Pin #	Usage/Description	Type/Dir Default
1	-	-	Ethernet RG45 connector PoE VC1 power	Power
2	-	-	Ethernet RG45 connector PoE VC2 power	Power
3	-	-	Ethernet RG45 connector PoE VC3 power	Power
4	-	-	Ethernet RG45 connector PoE VC4 power	Power

Legend	Ground	Power	Reserved

Table 3-10. PoE Backpower Header – J18

Pin #	Module Pin Name	Module Pin #	Usage/Description	Type/Dir Default
1	-	-	Main DC input supplying DC jack input (9 V-20 V). 3 A max.	Power
2	-	-	Ground	Ground

<b>Legend</b>	Ground	Power	Reserved
---------------	--------	-------	----------



# Chapter 4. Mechanical Specification

Figure 4-1 and Figure 4-2 show the mechanical dimensions for the carrier board and the developer kit.

The Developer Kit Weighs 0.175kg

Figure 4-1. Developer Kit Carrier Board Mechanical Dimensions

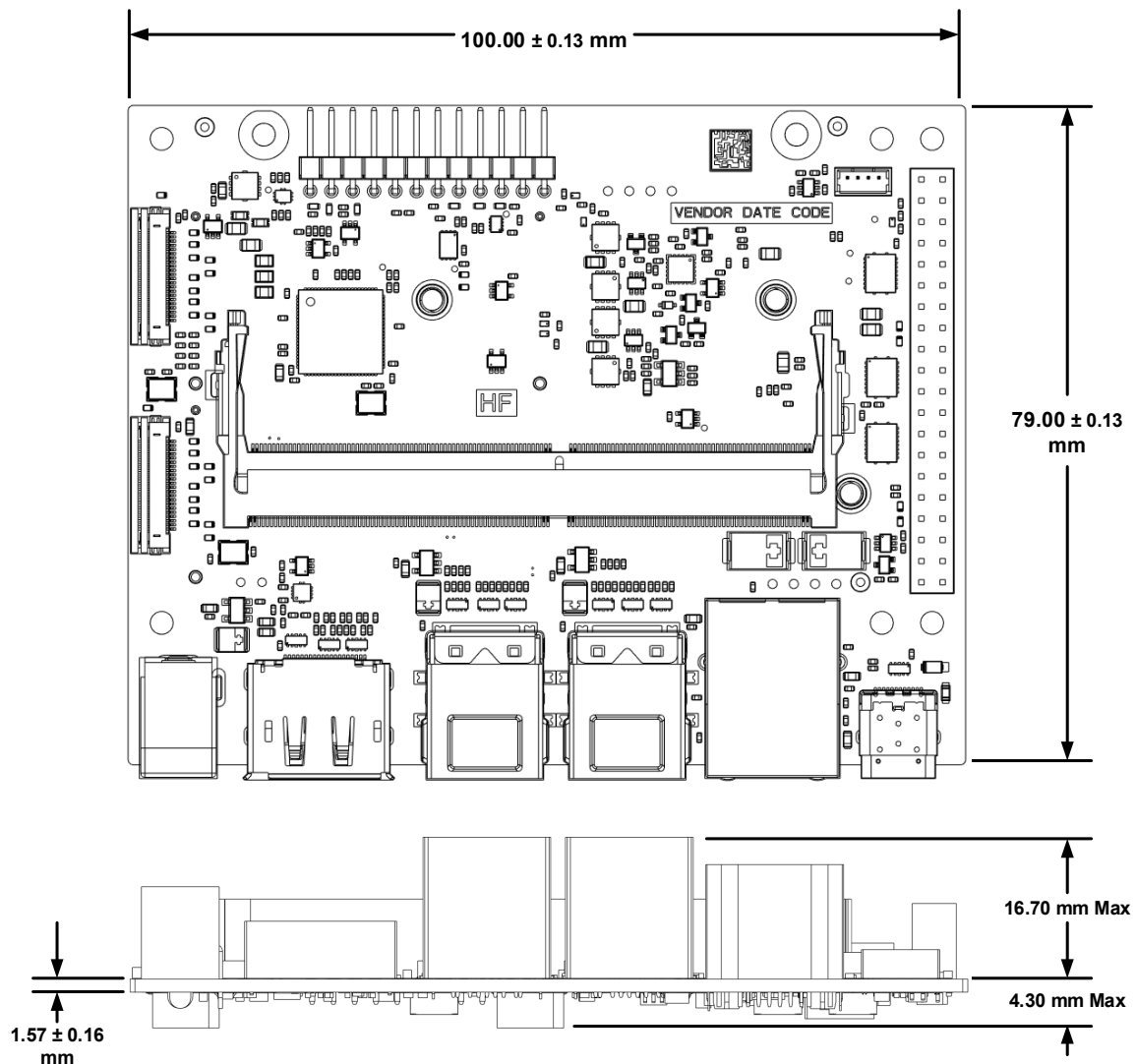
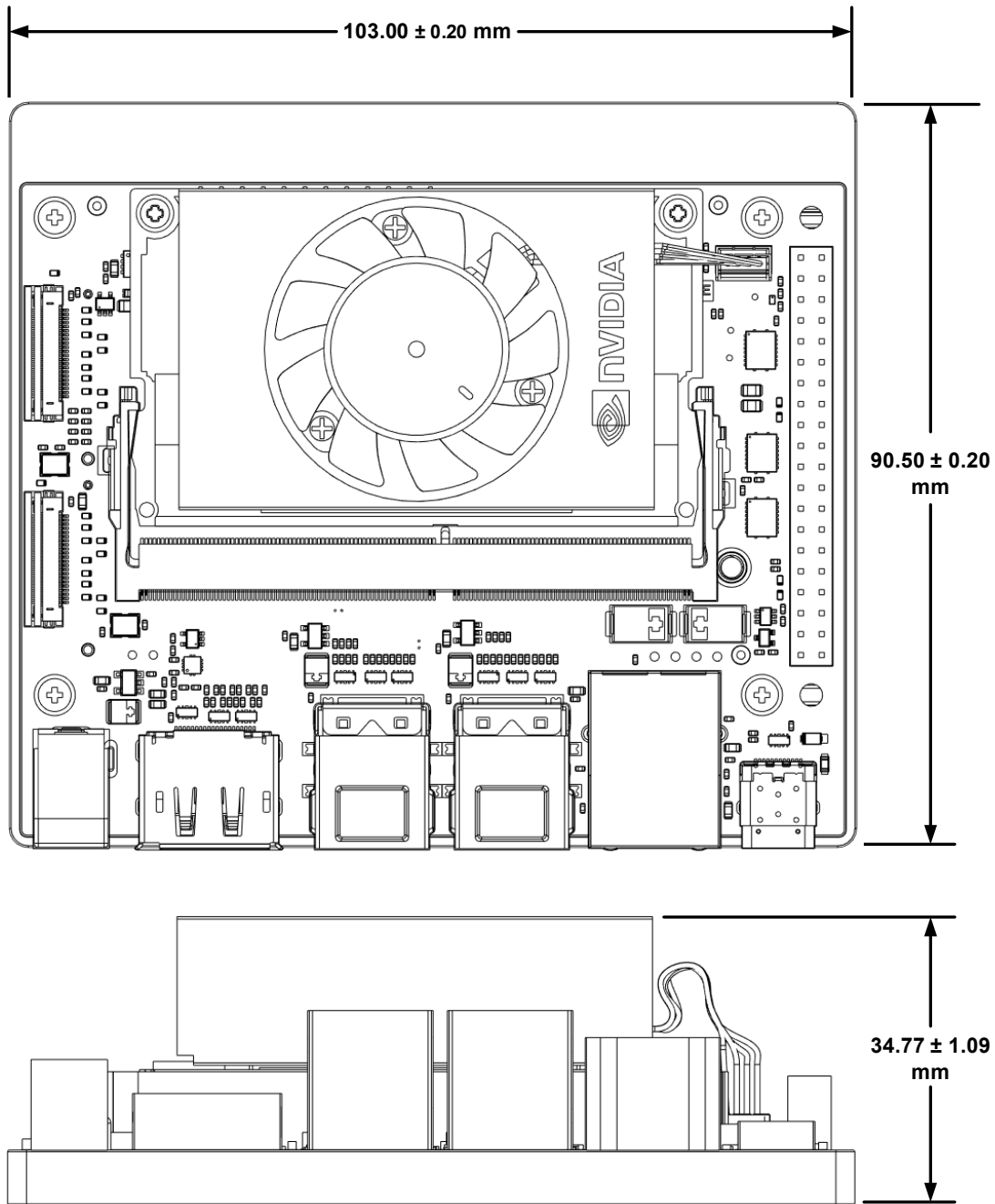

Figure 4-2. Developer Kit Mechanical Dimensions



# Chapter 5. Interface Power

Figure 5 1 shows the power diagram.

Figure 5-1. Power Diagram

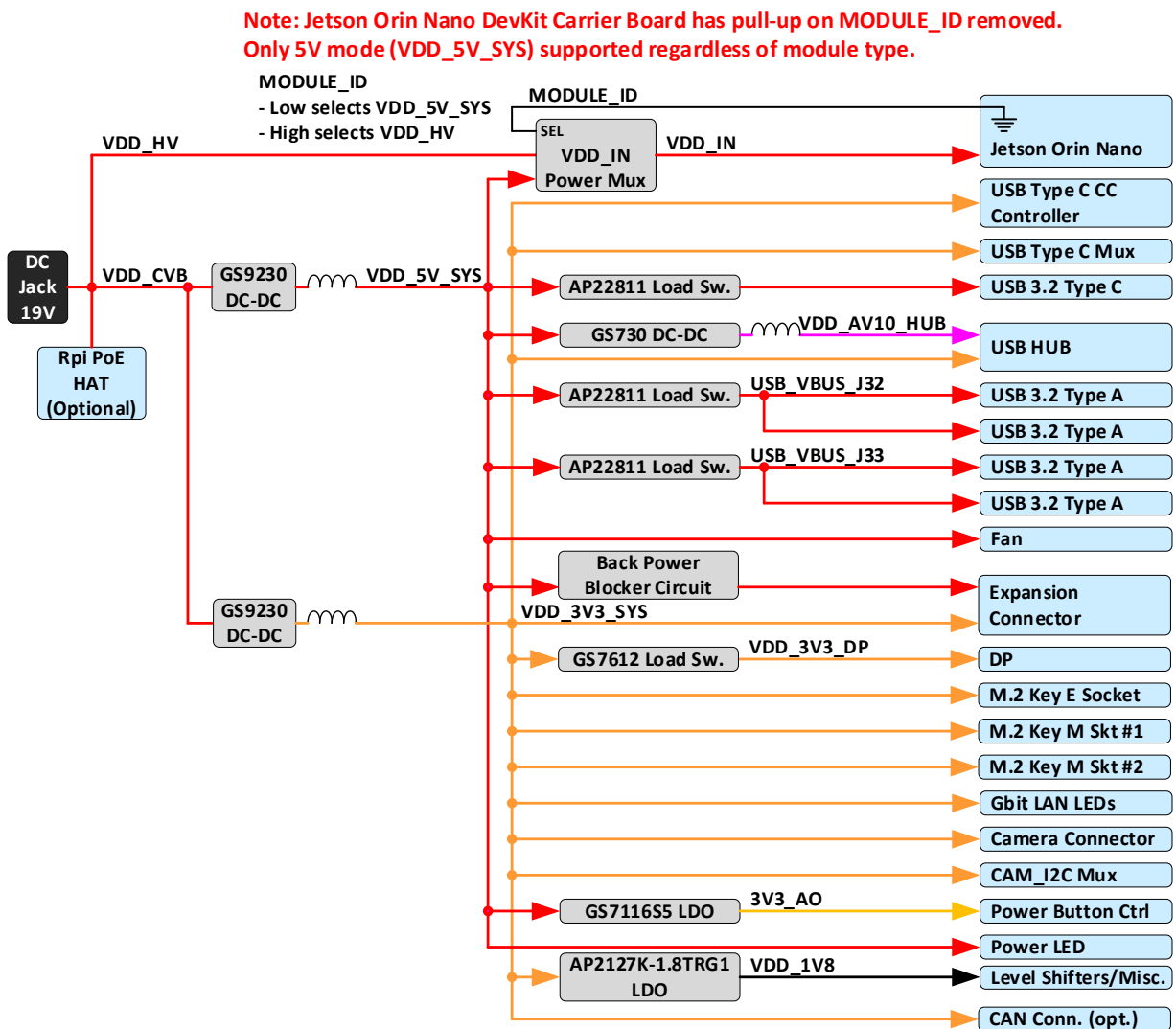

The following tables show the allocation of supplies to the connectors on the Jetson Orin Nano carrier board and current capabilities.

**Table 5-1. Interface Power Supply Allocation**

Power Rails	Usage	(V)	Power Supply or Gate	Source	Enable
DC_IN	Main power input from DC Adapter	19.5	AONR21357025 Power mux	DC Adapter	
VDD_5V_SYS	Main 5.0V supply	5.0	GS9230NVTQ-R	VDD_CVB (DC_IN after Power FET)	VDD_CVB
VDD_3V3_SYS	Main 3.3V supply	3.3	GS9230NVTQ-R	VDD_CVB	SYS_RESET_IN*
3V3_AO	Button MCU	3.3	GS7116S5-ADJ-R LDO	VDD_5V_SYS	VDD_5V_SYS regulator power good
VDD_1V8	Main 1.8V supply	1.8	AP2127K-1.8TRG1	VDD_3V3_SYS	3.3V_IO_PG
VDD_AV10_HUB	USB hub	1.1	GS7303ACTD-R	VDD_5V_SYS	VDD_3V3_SYS regulator power good
USBC_VBUS	5V VBUS for USB Type C connector	5.0	AP22811AW5-7	VDD_5V_SYS	ID from USB Type C CC controller
USB_VBUS_A	5V VBUS for dual stacked 3.0 Type A connector	5.0	AP22811AW5-7 Load Switch	VDD_5V_SYS	From USB Hub
USB_VBUS_B	5V VBUS for dual stacked 3.0 Type A connector	5.0	AP22811AW5-7 Load Switch	VDD_5V_SYS	From USB Hub
VDD_3V3_DP	3.3V rail for DP connector	5.0	GS7612S5MC-R Load Switch	VDD_3V3_SYS	VDD_3V3_SYS regulator power good

**Table 5-2. Interface Supply Current Capabilities**

Power Rails	Usage	(V)	Max Current (A)
DCJ_IN	Main power input from DC Adapter	19.0	4.2
VDD_5V_SYS	Main 5.0V supply	5.0	7.8
VDD_3V3_SYS	Main 3.3V supply	3.3	5.4
VDD_1V8	Main 1.8V supply	1.8	0.0002
3V3_AO	3.3V Always-on supply	3.3	0.200

**Table 5-3. Supply Current Capabilities per Connector per Supply**

Power Rails	Connector	(V)	Max Current (A)
VDD_5V_SYS	SO-DIMM (VDD_IN)	5.0	5.0
	40-pin header		0.5
	Fan connector		0.15
VDD_3V3_DP	DP connector		0.5
USBC_VBUS	USB Type C		0.5
USB_VBUS_A/B	USB 3.2 type A (x4)		0.5
VDD_3V3_SYS	40-pin header	3.3	0.1
	M.2 Key E socket		0.8
	M.2 Key M sockets (x2)		2.1
	Camera connectors (x2)		0.26

## Notice

This document is provided for information purposes only and shall not be regarded as a warranty of a certain functionality, condition, or quality of a product. NVIDIA Corporation ("NVIDIA") makes no representations or warranties, expressed or implied, as to the accuracy or completeness of the information contained in this document and assumes no responsibility for any errors contained herein. NVIDIA shall have no liability for the consequences or use of such information or for any infringement of patents or other rights of third parties that may result from its use. This document is not a commitment to develop, release, or deliver any Material (defined below), code, or functionality.

NVIDIA reserves the right to make corrections, modifications, enhancements, improvements, and any other changes to this document, at any time without notice.

Customer should obtain the latest relevant information before placing orders and should verify that such information is current and complete. NVIDIA products are sold subject to the NVIDIA standard terms and conditions of sale supplied at the time of order acknowledgement, unless otherwise agreed in an individual sales agreement signed by authorized representatives of NVIDIA and customer ("Terms of Sale"). NVIDIA hereby expressly objects to applying any customer general terms and conditions with regards to the purchase of the NVIDIA product referenced in this document. No contractual obligations are formed either directly or indirectly by this document.

Unless specifically agreed to in writing by NVIDIA, NVIDIA products are not designed, authorized, or warranted to be suitable for use in medical, military, aircraft, space, or life support equipment, nor in applications where failure or malfunction of the NVIDIA product can reasonably be expected to result in personal injury, death, or property or environmental damage. NVIDIA accepts no liability for inclusion and/or use of NVIDIA products in such equipment or applications and therefore such inclusion and/or use is at customer's own risk.

NVIDIA makes no representation or warranty that products based on this document will be suitable for any specified use. Testing of all parameters of each product is not necessarily performed by NVIDIA. It is customer's sole responsibility to evaluate and determine the applicability of any information contained in this document, ensure the product is suitable and fit for the application planned by customer, and perform the necessary testing for the application in order to avoid a default of the application or the product. Weaknesses in customer's product designs may affect the quality and reliability of the NVIDIA product and may result in additional or different conditions and/or requirements beyond those contained in this document. NVIDIA accepts no liability related to any default, damage, costs, or problem which may be based on or attributable to: (i) the use of the NVIDIA product in any manner that is contrary to this document or (ii) customer product designs.

No license, either expressed or implied, is granted under any NVIDIA patent right, copyright, or other NVIDIA intellectual property right under this document. Information published by NVIDIA regarding third-party products or services does not constitute a license from NVIDIA to use such products or services or a warranty or endorsement thereof. Use of such information may require a license from a third party under the patents or other intellectual property rights of the third party, or a license from NVIDIA under the patents or other intellectual property rights of NVIDIA.

Reproduction of information in this document is permissible only if approved in advance by NVIDIA in writing, reproduced without alteration and in full compliance with all applicable export laws and regulations, and accompanied by all associated conditions, limitations, and notices. THIS DOCUMENT AND ALL NVIDIA DESIGN SPECIFICATIONS, REFERENCE BOARDS, FILES, DRAWINGS, DIAGNOSTICS, LISTS, AND OTHER DOCUMENTS (TOGETHER AND SEPARATELY, "MATERIALS") ARE BEING PROVIDED "AS IS." NVIDIA MAKES NO WARRANTIES, EXPRESSED, IMPLIED, STATUTORY, OR OTHERWISE WITH RESPECT TO THE MATERIALS, AND EXPRESSLY DISCLAIMS ALL IMPLIED WARRANTIES OF NONINFRINGEMENT, MERCHANTABILITY, AND FITNESS FOR A PARTICULAR PURPOSE. TO THE EXTENT NOT PROHIBITED BY LAW, IN NO EVENT WILL NVIDIA BE LIABLE FOR ANY DAMAGES, INCLUDING WITHOUT LIMITATION ANY DIRECT, INDIRECT, SPECIAL, INCIDENTAL, PUNITIVE, OR CONSEQUENTIAL DAMAGES, HOWEVER CAUSED AND REGARDLESS OF THE THEORY OF LIABILITY, ARISING OUT OF ANY USE OF THIS DOCUMENT, EVEN IF NVIDIA HAS BEEN ADVISED OF THE POSSIBILITY OF SUCH DAMAGES. Notwithstanding any damages that customer might incur for any reason whatsoever, NVIDIA's aggregate and cumulative liability towards customer for the products described herein shall be limited in accordance with the Terms of Sale for the product.

## Trademarks

NVIDIA, the NVIDIA logo, Jetson, Jetson Orin Nano, and NVIDIA Orin are trademarks and/or registered trademarks of NVIDIA Corporation in the U.S. and other countries. Other company and product names may be trademarks of the respective companies with which they are associated.

## VESA DisplayPort

DisplayPort and DisplayPort Compliance Logo, DisplayPort Compliance Logo for Dual-mode Sources, and DisplayPort Compliance Logo for Active Cables are trademarks owned by the Video Electronics Standards Association in the United States and other countries.

## HDMI

HDMI, the HDMI logo, and High-Definition Multimedia Interface are trademarks or registered trademarks of HDMI Licensing LLC.

## Copyright

© 2023 NVIDIA Corporation. All rights reserved.